

An Effective 80 and 40 Meter SSB/CW Receiver

*Something old and something new in a
homebrew dual-band receiver.*

By Dave Lyndon, AK4AA

There is no limit to the number of possible architectures for amateur-band receivers. This is yet another entry, an 80- and 40-meter SSB/CW receiver that uses modern technology (something new) to implement a high-performance design in a small package with its roots in the 1950s and 60s (something old). In addition, there's something borrowed, too. Although relying heavily on ARRL *Handbooks* and personal experience, much of the circuitry was borrowed from others without embarrassment. (I only steal from the very best! See the references at the end of this article for acknowledgements.) It has

noise-figure, dynamic-range, and intermodulation performance as good as most high-quality commercial receivers, and it's better than many.

The receiver is kept as simple as possible without sacrificing performance by foregoing optional bells and whistles. However, it is not a weekend project, nor a task for the faint-hearted. It will take some time and patience to duplicate, but the result will be rewarding—and relatively inexpensive, too. New parts are readily available from various sources on the Internet and can be purchased for less than \$200. A well-endowed junk box will reduce that considerably. You will also need some test equipment to make various adjustments. My test bench is quite modest: an inexpensive digital multimeter, a 20 k Ω /V analog multimeter, an old Heathkit audio sig-

nal generator, an even-more-ancient Heathkit RF signal generator, a “bottom-of-the-line” frequency counter, a vintage 20 MHz dual-channel oscilloscope and a homebrew inductance meter described in Reference 8. You can get through this project with less equipment, but I found the scope and counter invaluable. It's amazing what can be accomplished with reasonably simple tools.

Fig 1 is a photograph of the completed receiver, and Fig 2 is the block diagram. The antenna is connected to the first mixer through passive filters that select either the 80- or 40-meter band. The local oscillator is a VFO, tunable from 5.2 to 5.7 MHz.

Signals either from 3.5 to 4.0 MHz or 6.9 to 7.4 MHz (7.0 to 7.3 MHz is the 40-meter amateur band) are down-converted to a common intermediate

85 Woody Farm Rd
Hot Spring, NC 28743
dlyndon@director.com

frequency of 1.7 MHz depending on which input filter is selected. A low-noise IF amplifier with manual gain control provides sufficient amplification to compensate for the losses of the first and second mixers, thus establishing a noise figure suitable for these bands, which are dominated by atmospheric rather than receiver noise. Consequently, there is no need for an RF preamplifier, which, if present, would very likely reduce the dynamic range and increase inter-modulation distortion.

From this point forward, the design is that of a 1.7-MHz direct-conversion receiver using the phasing method of sideband selection. The output of the IF amplifier is in phase simultaneously to two mixers. The local oscillator for those mixers is a 1.7-MHz oscillator that tunes ± 3 kHz. In earlier ham parlance, we would have called this the beat frequency oscillator (BFO), and we shall use that terminology here. Once a signal is tuned in with the VFO, a very-fine tuning adjustment can be made with the BFO tuning control if desired. After isolating amplifiers, a hybrid phase shifter provides two LO signals in phase quadrature (90° out of phase) to the I (in phase) and Q (quadrature) second mixers.

The resulting low-level I and Q channel baseband (audio) signals, 90° out of phase, are amplified by nearly identical low-noise amplifiers, and then fed to I and Q audio phase-shift networks that have a 90° phase difference over the band of interest, 300-3000 Hz. By adding or subtracting the resulting phase shifted audio signals in an opamp, we select the upper or lower sideband.

Once the I and Q baseband signals have been combined, the SSB bandwidth is established by 3000 Hz low pass and 300 Hz high pass passive filters. Since there is no automatic gain control, a manual audio-gain control sets the level prior to further processing to use the full dynamic range of the preceding circuitry without overloading subsequent stages. For CW, a three-pole active filter with a 600-900 Hz passband may be switched into the signal path. Another circuit mutes the receiver during transmit periods, and an optional reed relay protects the first mixer from strong transmit/receive relay leakage. Line-level audio output is available for further external audio processing, and a minimal IC audio amplifier is included with sufficient power to drive headphones or a speaker. It is preceded by a secondary audio level control that does not affect the line output level.

One of the obstacles to building a receiver with a manually tuned VFO is a suitable mechanical tuning mechanism for the variable capacitor. Hard to find today, they were once ubiquitous in various forms (more something old), but not to worry. With hand tools and a soldering iron you can build your own from a coffee can, an old potentiometer, a spare tuning

knob, a small spring, and a bit of dial cord. Don't laugh. Historically scorned by hams, this dial drive provides a 16 to 1 turns ratio with exceptionally smooth tuning, rock-solid positioning, and absolutely no discernable backlash. Its construction is described in the Appendix for the adventuresome.

The circuitry was arranged in functional groups on five circuit boards:



Fig 1—The completed receiver.

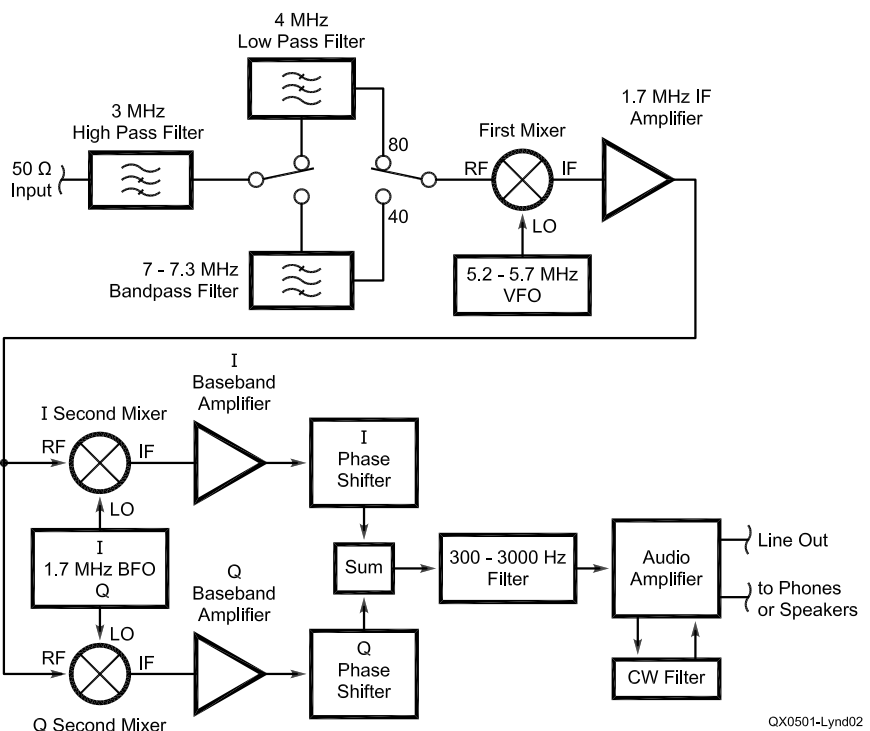

Fig 2—The receiver block diagram.

(1) the RF/IF Board, (2) the Oscillator Board in its own minibox, (3) the Baseband Amplifier Board, (4) the Phase Shifter/Filter Board, and (5) the Audio Board. Details of each board and its associated chassis components follow; you can look to the references for further elaboration. Since there are many toroidal inductors in the receiver, you should read my suggestions on winding toroidal inductors with magnet wire in the sidebar, "Toroid Winding Tips."

RF/IF Board (Fig 3)

This board was constructed on a

single-sided circuit board using "ugly" and "dead-bug" methods. The copper foil is a ground plane to which ground connections can be made directly. Other connections are supported by standoffs (1 M Ω resistors with one end soldered to the ground plane) where required.

The first filter section is a 50- Ω high-pass filter with its cutoff just below the 80-meter band. It rejects strong broadcast-band signals below 3 MHz in all but the most severe environments, and it remains in the signal path when switching to the 40-meter band for that same purpose.

A 50- Ω low-pass filter (cutoff just above 4 MHz) is switched in for the 80-meter band. This elliptical filter has a sharp cutoff to reject the image frequencies between 6.9 and 7.4 MHz. The insertion loss in the passband of the first and second filter sections in series is about 1 dB.

The 40-meter filter consists of a high-pass elliptical filter with a 6.9 MHz cutoff (needed to reject the 80-meter image) followed by two capacitively coupled parallel-tuned circuits. The inductors are tapped to obtain 50- Ω input and output impedances, while retaining the high Q needed for good

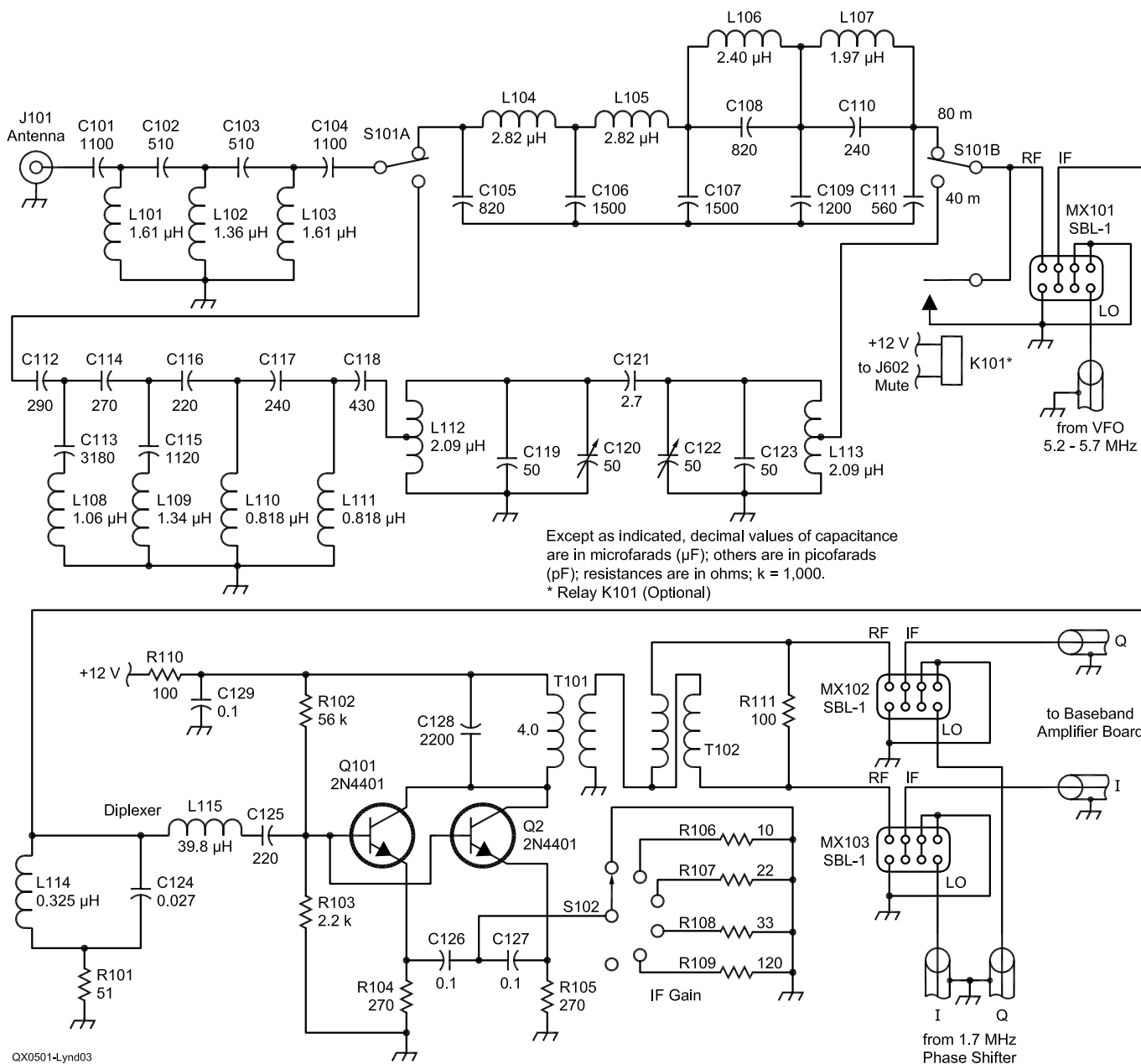

Fig 3—The RF/IF board.

selectivity. The circuits are stagger-tuned with their variable capacitors set for flattest response over the 7.0-7.3 MHz range. When properly adjusted, the image frequencies for either band are rejected by at least 60 dB (good enough) and theoretically 80 dB. I don't have the equipment to confirm that level of rejection was achieved, but my crude measurements were encouraging. The sharp-cutoff elliptical filters make this possible, so Table 1 includes the design resonant frequencies for the elliptical sections of the filters, and it is advisable to measure them before connection.

The SBL-1 doubly balanced diode first mixer down-converts the selected-input signal band to the 1.7-MHz IF when mixed with the VFO local oscillator. The LO level is +7 dBm, adjusted as described in the "Oscillator Board" section. Higher-order mixing products are safely outside this IF, so spurious "birdies" are absent. This small device is held in place on the board in dead-bug style by soldering bare wire from two opposite-end ground pins directly to the ground plane. A TUF-1 mixer

could be used instead of the SBL-1, and it is quite a bit smaller.

The 1.7-MHz IF amplifier is two low-noise NPN transistors wired in parallel with some shunt feedback, and it provides the low input impedance necessary to properly terminate the first mixer. Proper termination insures the low intermodulation distortion needed to detect weak signals in the vicinity of strong signals, so a diplexer is used to send frequencies below and above 1.7 MHz to a 50 Ω resistive load and to pass 1.7 MHz to the 50-Ω amplifier input. The 1.7-MHz series-resonant frequency of L115 and C125 should be verified by measurement. Inexpensive 2N4401 transistors are ideal for this application, and 2N2222s are almost as good. Very narrow bandwidth is not required here, so the output load is a single parallel-tuned circuit, the primary of an RF transformer. The untuned secondary of this RF transformer drives a bifilar power divider that feeds two equal, in-phase signals to the I and Q SBL-1 mixers. Each winding presents a 50-Ω output impedance in combina-

tion with the 100-Ω isolating resistor, R111.

The IF gain can be reduced manually for very strong signals prior to baseband detection and audio amplification, thus increasing the dynamic range. The gain is changed by switching in resistors that change the emitter degeneration for RF without affecting the dc bias. Higher resistances provide more degeneration and lower the gain. With the resistance values shown, the gain is adjustable from about +23 dB to 0 dB in roughly 5 dB steps. The conversion loss and noise figure of each mixer when properly terminated. The IF gain is sufficient to overcome those losses while adding less than 2 dB to the overall receiver noise figure. Lacking suitable measurement equipment to confirm it absolutely, I estimate the Noise Figure of the receiver to be about 12 dB, more than adequate for these environmentally noisy bands.

The SBL-1 I and Q doubly balanced diode mixers receive their independent LO signals from the BFO phase shifter described in the "Oscillator

Table 1
Coil-Winding Data

SYMBOL	VALUE	FORM	TURNS	WIRE SIZE (AWG)	REMARKS
L101	1.61 μH	T37-6	22	26	
L102	1.38 μH	T37-6	19	26	
L103	1.61 μH	T37-6	22	26	
L104	2.82 μH	T50-6	25	24	
L105	2.82 μH	T50-6	25	24	
L106	2.40 μH	T50-6	22	24	Resonates with C108 at 11.4 MHz
L107	1.97 μH	T50-6	20	24	Resonates with C110 at 7.44 MHz
L108	1.06 μH	T37-6	16	26	Resonates with C113 at 2.74 MHz
L109	1.34 μH	T37-6	18	26	Resonates with C115 at 4.10 MHz
L110	0.818 μH	T30-6	15	28	
L111	0.818 μH	T30-6	15	28	
L112	2.09 μH	T30-6	22/4	28	22 turns tapped at 4 turns
L113	2.09 μH	T30-6	22/4	28	22 turns tapped at 4 turns
L114	0.325 μH	T25-2	3	24	Resonates with C124 at 1.7MHz
L115	39.8 μH	T68-2	84	30	Resonates with C125 at 1.7MHz
T101	4.0 μH	T50-2	28 & 16	24	Primary resonates with C128 at 1.7MHz
T102	6.72 μH*	FT37-43	4 & 4	24	4 turns, bifillar-wound transformer
L201	11.2 μH	Slug Tuned	40	26	1/2-inch OD ceramic slug-tuned coil form
L202	1000 μH*	FT37-43	48	32	broadband RF choke
L203	18.3 μH	T80-6	60/15	28	60 turns tapped at 15 turns
T201	168 μH*	FT37-43	20 & 4	28	Broadband transformer
T202	82.3 μH*	FT37-43	14 & 14	28	14 turns bifillar transformer
T203	4.70 μH*	T50-2	31 & 31	30	13 turns bifillar hybrid transformer
L301	47 mH	PC-1408-77	155	36	2 required, matched
L302	1.2 mH	FT37-77	35	30	2 required, matched
L401	137 mH	PC-1408-77	260	36	
L402	40.5 mH	PC-1408-77	144	36	
L403	40.5 mH	PC-1408-77	144	36	

*Use the number of turns given. The inductance value is approximate, not critical.

Board" section. These levels, too, are + 7 dBm for best performance. These devices are held in place as dead-bugs also by soldering bare wires from two opposite-end ground pins directly to the ground plane. The outputs of the I and Q mixers are fed directly to matched amplifiers on the Baseband Audio Board.

Oscillator Board (Fig 4)

This board is also ugly construction on a single-sided board. The series-tuned Colpitts VFO (remember those?) uses an MPF102 JFET operating from + 6 V regulated by a Zener diode. Output level is sacrificed for the frequency stability for which this circuit is noted. All capacitors in this circuit are zero-temperature-coefficient (NP0) ceramics. The tuning capacitor is an old-fashioned 15 to 365 pF non-linear capacitor with good mechanical stabil-

ity (again, something old). Its characteristic (approximately capacitance squared versus rotation) provides a reasonably linear dial in this circuit. Such capacitors are available from Internet suppliers or possibly through junk-box trading. The one I used was a small two-section type, wired in parallel to give the required capacitance. The VFO inductor is the only slug-tuned inductor in the receiver; use a high-quality ceramic coil form. For best temperature stability, the number of turns is such that the slug is just barely into the winding, thus minimizing its contribution to temperature drift while providing sufficient adjustment to set the VFO frequency. Alternatively, a toroidal inductor could be used here. Type-6 powdered-iron material has the best temperature stability, although not as good as the tunable coil inductor. A

trimming capacitor would be needed in that case; but since most miniature trimmers are not very stable, the slug-tuned inductor with fixed capacitors (other than the tuning capacitor) seems a better choice.

The frequency range is established by the fixed capacitors in parallel with the variable capacitor. Select the fixed capacitors for a bandspread just slightly wider than the required 5.2-5.7 MHz.

An MPF-102 JFET source follower isolates the oscillator from subsequent load variations. The output level needed from the subsequent transistor amplifier is +7 dBm into 50 Ω. Adjust the level by changing the small coupling capacitor from the source follower to the amplifier. Temporarily connect a 50-Ω resistive load, and once the level is set, remove the 50-Ω load and connect the output to the first mixer's

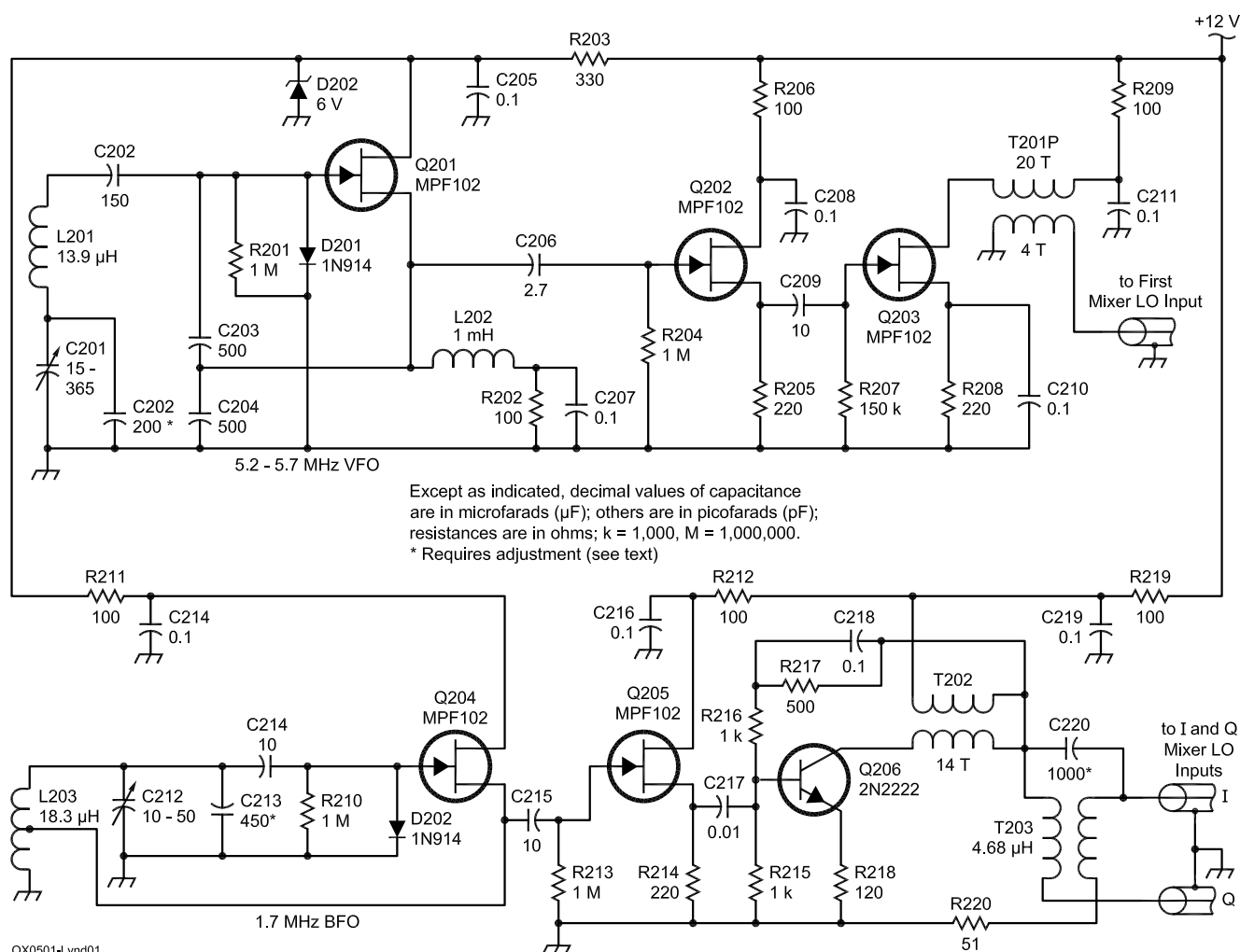

Fig 4—The Oscillator board.

LO terminal. Lacking a power meter, I adjusted the level to 1.4 V_{P-P} with a broadband oscilloscope (1.4 V_{P-P} = 0.7 V_{PK} = 0.49 V_{RMS} = 4.8 mW into 50 Ω = +6.9 dBm.) The frequency variation from cold start to operating temperature in 70° F ambient was less than 500 Hz in the first half hour. After that, it was less than 50 Hz over a considerable period. Long contacts will not require retuning. That's not too bad for mostly junk-box parts!

The 1.7-MHz BFO is a conventional Hartley oscillator also using an MPF-102 JFET operating from the +6 V Zener. In this case, a type-6-material toroid is suitable. (The 1.7-MHz frequency is a smidge lower than recommended for high Q.) It is held securely in place upright by a plastic tie-wrap inserted through a small hole in the circuit board, looped through the tor-

oid, routed back through the hole, and pulled taught through the locking slot of the tie-wrap. At 1.7 MHz, the frequency drift is as good as the VFO and tends to be in the opposite direction. The total drift is quite acceptable for both SSB and CW. Again, NP0 ceramic capacitors were used throughout, except for a small front-panel-mounted variable capacitor, C212, that is connected to the oscillator tank via a miniature shielded coaxial cable. The capacitance of the cable, 10 pF or so for about 4 inches, becomes a part of the tuned circuit, so it must be stable. I used a short length of one of the two small 72-Ω coax cables in an S-video cable. With the variable capacitor at its center position, the BFO center frequency is set to 1.7 MHz by selecting fixed NP0 capacitors and a small trimmer included for final adjustment. At

this lower frequency, it is stable enough. The approximate values shown provided front-panel tuning of ±3 kHz after removing a couple of rotor plates from the capacitor I had on hand to get the required range.

The oscillator is followed by a JFET source follower for load isolation then an NPN transistor amplifier. The amplifier is a widely used low-output-impedance broadband circuit. Its gain is established by the ratio of resistors R217 and R216; the former is bypassed for RF, the latter is not. A larger R216 reduces RF feedback and increases the gain; a smaller R216 increases the RF feedback and lowers the gain. The total series resistance of R217 and R216 must be kept the same to properly bias the transistor. We need about +10 dBm of output (2.0 V_{P-P} on the oscilloscope feeding a temporary 50-Ω resistor) to

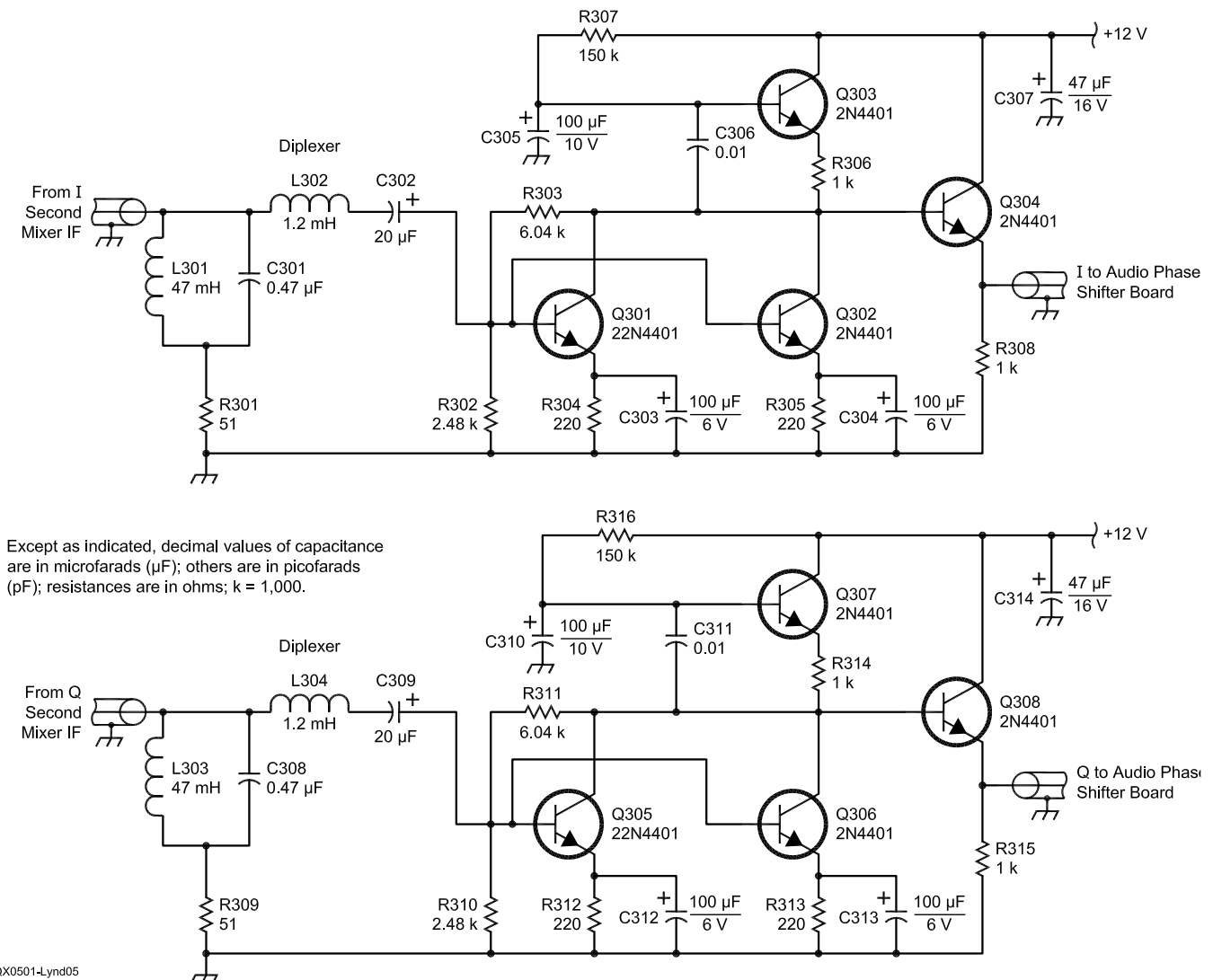

Fig 5—The baseband (audio) board.

provide +7 dBm LO signals out of the hybrid phase shifter to each of the two baseband mixers, and the component values shown should yield that result approximately.

A twisted-wire hybrid phase shifter, described in Reference 4, was used to divide the +10 dBm signal into two +7 dBm signals in phase quadrature. There are several possible RF phase-shift networks; but this circuit, while analytically mysterious, is simple to construct and requires no adjustment over a wide frequency range. This variant uses a single capacitor rather than two but is electrically equivalent to the original described in the reference. Precise 90° phase shift can be achieved by adjustment of the capacitance as described below. Its output levels change with frequency but remain 90° apart to enable excellent sideband rejection. With the values shown, the two outputs near 1.7 MHz will be nearly equal, about +7 dBm (1.4 V_{P-P}) when terminated with individual 50-Ω resistors. Once the levels are set by adjusting the gain of the amplifier, remove the terminating resistors and connect the outputs to the I and Q baseband mixers' LO terminals.

Baseband Audio Board (Fig 5)

This is the third ugly construction board. This board and part of the following board are stolen from the excellent designs of Glen Leinweber, VE3DNL, noted in Reference 4. Much of this work was based on the earlier work of Rick Campbell, KK7B, as cited in the references.

As Campbell and Leinweber have so eloquently informed us, the I and Q mixers must be properly terminated at all frequencies to provide the desired performance. For this purpose we use a diplexer that routes signals below 300 Hz and above 3000 Hz to a 50-Ω terminating resistor, while signals of interest are sent to an audio amplifier with 50-Ω input impedance. We need a lot of low-noise audio gain because the weakest signals from the I and Q mixers will be in the microvolt range. Furthermore, the diplexers and audio amplifiers in the I and Q channels must match each other as closely as possible to achieve good unwanted-sideband rejection. For that reason, we use 1%-matched components in the two channels. We can compensate for minor gain imbalance downstream, but phase-shift balance of 1° or better is required for good sideband rejection.

Fig 6 (Right) —The phase shifter/filter board.

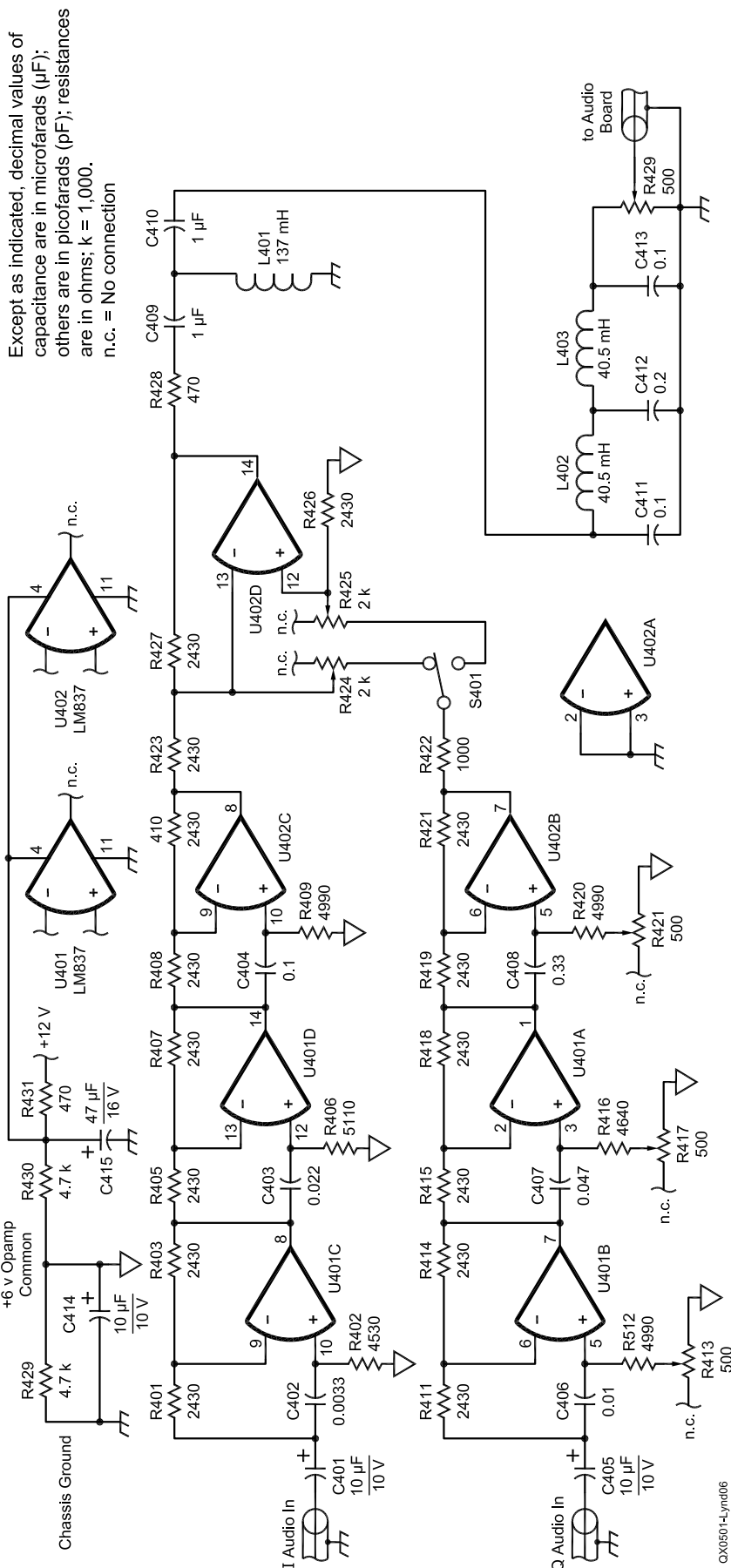

0X0501-Lym06

On the advice of Leinweber, I used PC1408-77 pot cores available from Amidon to get high inductance with reasonable Q. Careful attention to equal turns count and equal plastic mounting-screw pressure will yield the desired result. Be careful not to over tighten the hardware because the cores are fragile, as I discovered to my regret. The exact inductance value is less important than is matching (equal values). If suitable test equipment is available, the inductor values should be measured. The most phase-critical components in the diplexers, however, are the series-tuned LC circuits that pass the audio frequencies to the amplifiers. You can check the amplifiers' phase shift by driving both channels with the same 1000-Hz audio signal at the diplexer inputs and observing the sum of the amplifier outputs on a dual-channel scope, with one channel inverted and the scope channel gains adjusted for the best null. Then check for nulls at 300 Hz and 3000 Hz with the same signal connected to both inputs. If there is not a good null at both frequencies, there is a phase difference in the channels, and it is more than likely caused by imbalance in the diplexers. In that case, you must adjust the inductance, capacitance or both in one channel or the other. The phase shift at 300 Hz is affected mostly by the series capacitance, so adding capacitance to one channel or the other will improve the low-frequency null. Similarly, the series inductor will dominate the phase shift at 3000 Hz, and it may be necessary to unwind a few turns on one inductor or the other to get a good high-frequency null. A final check using a Lissajous pattern (if your scope is so endowed) will show a straight line at 45° with no ellipticity (separation) over the audio range.

Phase Shifter/Filter Board (Fig 6)

This board and the Audio Board are built on prefabricated integrated-circuit experimental boards. Sockets were used for the integrated circuits although the devices could be soldered in directly at the risk of damaging them. Perfboard may even be preferable because the pads on prefab circuit boards are difficult to solder and may lift off. For the ambitious, a custom printed circuit board could be developed. Perhaps I would do that (for all the boards) if there is sufficient interest.

The I and Q audio phase shifters are implemented with quad low-noise op amps. The theory of operation is beyond the scope of this article; but with careful adjustment, the receiver

is capable of at least 40 dB of unwanted sideband rejection. With extra care and patience 50 dB is possible, and 60 dB can be achieved with realizable components.

It is important to use stable 1%-tolerance capacitors in this network, and several types are available. I used polystyrene capacitors, although they are pricey and undesirably large. Trimming resistors in the Q network are used to finely adjust the phase shift. Leinweber describes a method for adjusting these trimmers using a homebrew quadrature square-wave oscillator; I shall suggest a simpler method below.

The entire receiver operates from a single +12-V power supply, but the op amps require both positive and negative supply voltages. To avoid the complexity and expense of dual power supplies, an artificial signal common is established +6 V above chassis ground using a "stiff" voltage divider. Thus, voltages +6 V above and -6 V below the signal common potential are established.

Outputs of the I and Q phase shifters are summed in an op amp to reject one sideband. By switching the Q output to the non-inverting input—in effect shifting its phase 180°—the opposite sideband is rejected. The re-

sulting SSB signal is then filtered by a 500-Ω passive network consisting of a five-pole 3000-Hz low-pass filter and a three-pole 300-Hz high-pass filter implemented with pot-core inductors and stable capacitors. A 500-Ω potentiometer terminates the network and is the audio gain control.

Adjustment requires a pair of audio signals in phase quadrature at 3400, 715, and 295 Hz, in turn. The Leinweber method uses a homebrew circuit to create these signals as square waves (see Reference 4), but harmonic filtering is required to observe the fundamental only. Another method is to use the front end of the receiver itself to generate the quadrature audio signals. I found that both methods give nearly the same result. It relies on the 1.7 MHz hybrid phase shifter's correct LO phase relationships, so initially we must trust in that circuit's performance prior to final adjustment.

Insert a low-level 80-meter signal from an RF signal generator or test oscillator at the antenna input. While monitoring the signal at the audio-gain control with the scope, tune the receiver to obtain an audio output. That audio frequency can be measured with a frequency counter or by comparison with an accurate audio oscillator us-

Toroid Winding Tips

The enamel must be removed from the wire, of course, for solder connections where required, either chemically or by scraping with a sharp knife. I prefer the latter method. For mechanical stability I recommend that the first and last turn on each inductor be "tucked under" itself and pulled taught, taking care not to damage the enamel, which would short the turn. The inductance of these toroids can be adjusted over a range of ±5% or so by spreading or compressing the turns. The number of turns and their spacing is more important than the wire size, so one should generally use the largest wire that will fit comfortably on the core and allow for some adjustment. For maximum Q, the winding should cover only about 3/4 of the core circumference. Turns-versus-inductance formulas for these toroids are approximations. It may be necessary to add or remove turns to achieve the desired inductance. I have found the formulas generally call for too many turns, so inductance measurement is required. One method for doing this was described in my QEX article (Reference 8). For the bifilar windings specified, twist two lengths of magnet wire together with about eight turns per inch. This insures that the two windings are closely coupled, of the same length and same number of turns. Once the inductance is correct, generously apply coil dope to prevent winding movement. Clear nail polish works very well for this purpose. Table 1 provides the turns and wire sizes actually used for the inductors and RF transformers in the receiver.

The receiver uses several pot-core inductors, available from Amidon, for the higher inductances values required in the audio circuits. Many turns (hundreds) of very fine magnet wire must be wound on the plastic bobbin provided with the cores. That fine wire is fragile and difficult to connect externally. Borrow a technique used in transformers: Strip and wind an inch or so of each fine-wire end over the stripped end of a larger-diameter insulated wire, solder the joint, coat the connection with coil dope (nail polish) for insulation and wind the last few coil turns with the larger wire, which serves as a lead for the transformer. To prevent slippage of the winding, the final turn is "looped under" and pulled taught as is done for the toroids. Apply a coat of dope over the winding.

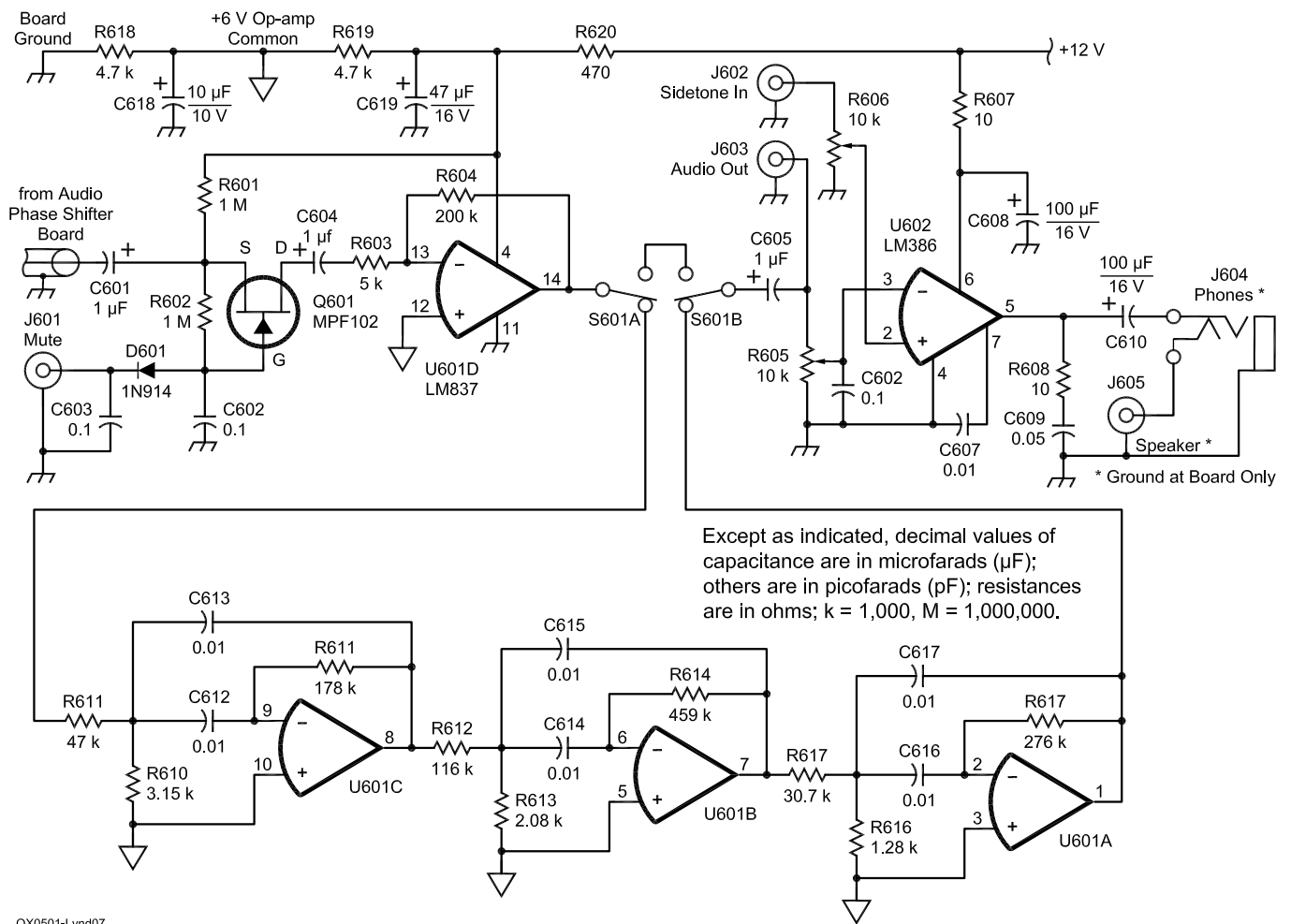

Fig 7—The audio board.

ing a Lisajous presentation on the scope, or it can be estimated by using the scope's time base. Tune the receiver to obtain a 3400-Hz audio signal (the BFO tuning will come in handy here), and then switch the sideband selector. The opposite sideband amplitude should be significantly lower. First, adjust the balance control, R424 or R425, whichever has an effect, for a null, increasing the scope gain as necessary to observe the weak signal at null. Next, adjust R406 for a null, and then adjust these two controls alternately for best null. Now retune the receiver slightly to the opposite sideband and obtain a 3400-Hz signal in the sideband previously rejected. Switch the sideband selector and adjust the other balance control, R425 or R424, for a null in the new rejected sideband. Similarly, obtain signals at 715 and 295 Hz by retuning the receiver and adjust R406 and R409, respectively, without disturbing the



Fig 8—The VFO tuning capacitor inside, mounted on the front of the more-rigid box section that has the folded tabs.

amplitude-balance controls. With generous portions of care and patience, iteration of these five adjustments will yield optimum performance.

If good nulls of approximately equal rejection cannot be obtained on both upper and lower sidebands using the sum and difference balance adjustments only with common audio phase shifter adjustments, the 1.7-MHz hybrid phase shifter may not be providing signals exactly 90° out of phase. Add (or subtract) a bit of capacitance to C 220 in increments of about 50 pF and try again at 4300 Hz. When the hybrid's outputs are in phase quadrature, it should be possible to get both upper and lower sideband rejection of at least 40 dB (100:1 voltage ratio between sidebands) with the same set of phase adjustments in the audio phase shifter. I got 46 dB without much trouble, and 50 dB with a little patience.

Audio Board (Fig 7)

Another stiff voltage divider is used to establish an artificial signal common at +6 V for this board's op amps. The signal passes first through a JFET transistor used to mute the receiver during transmit by grounding the cathode of diode D601 to bias the transistor off. The following stage is an op amp with 26 dB gain to raise the signal to a line level suitable for external audio processing.

The three-pole band-pass active filter may be switched into the signal path for CW reception. It has a 3-dB bandwidth of 400 Hz centered on 750 Hz. The resistor values were chosen such that all capacitors in the filter are the same value, 0.01 μ F. They need not be this exact value, but their values should match within 3% for best filter performance. The non-standard resistance values are series/parallel combinations of resistors as measured with a DMM. Notice that each stage's input signal is attenuated; these band-pass stages have considerable gain that must be compensated to avoid downstream overload. The overall gain of the filter is about 10 dB, and that provides a reasonable balance of audible signal level when switching the narrow filter in and out. A secondary audio-gain control is provided to set the level for the optional IC headphone and speaker amplifier that follows. This amplifier will also accept an input for a CW sidetone if desired.

Power Supply

A single external +12 V source is required. It must supply about 100 mA, but if the on-board audio power ampli-

fier is used to drive a speaker, the current will peak to twice that value at full volume. Obviously, the receiver is well suited for field or emergency operation since it can be operated from a 12 V battery.

Construction (Figs 8 through 11)

The receiver is housed in a 5×10×3 inch aluminum chassis (Bud BPA-1591 or equivalent) with the 5×10 inch surface as the front panel. A window in the front panel allows viewing a portion of the rotary dial. Of course, a more exotic (and expensive) enclosure could be used, and a bit more space would be a welcome luxury. Nevertheless, this is a description of the receiver

as actually constructed.

The phase shifter/filter board is mounted inside the chassis on one end and the audio board on the bottom, both with ¼-inch standoff hardware to hold the boards' underside wiring off the chassis. They are positioned to allow clearance for the minibox assembly described below. The SIDEBAND selector switch and the main AUDIO GAIN control are the front panel controls associated with the phase shifter/filter board, and they are mounted on the front panel near that board. Similarly, the headphone/speaker VOLUME control, the ungrounded speaker and headphone jacks, and the CW filter switch are mounted on the front panel

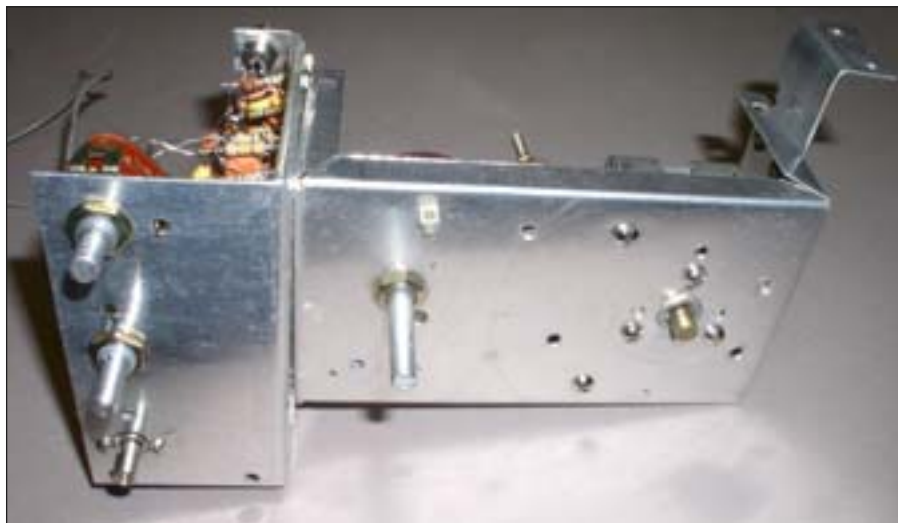

Fig 9—The rotary dial drive outside the front of the more-rigid box section.



Fig 10—The RF/IF board is mounted outside the minibox on an L-shaped aluminum bracket attached to one end of the oscillator minibox.

near the audio board. These front-panel controls are wired to the boards before mounting them inside the chassis, and they must be positioned to leave space for the rotary dial.

The oscillator board is mounted in a separate aluminum “minibox.” Figs 8 and 9 show the VFO tuning capacitor inside and rotary dial drive outside, mounted on the front of the more-rigid box section that has the folded tabs. The box itself is secured $\frac{3}{4}$ inch behind the receiver front panel to allow space for the rotary dial. The dial driveshaft is long enough to pass through a clearance hole in the front panel for fitting of the main tuning knob. Since the VFO frequency may be affected slightly when the rear cover is installed, a hole in the cover provides access to the VFO inductor for final adjustment.

An L-shaped aluminum bracket attaches to one end of the oscillator minibox as shown in Fig 10, and the RF/IF board is mounted outside the minibox on this bracket with the same mounting screws. Small holes are drilled through the board, bracket and minibox through which pass wires from the oscillators to the mixers, to the VFO via small coax and to the BFO with short insulated wires. The oscillator board receives +12 V through a small hole, bypassed with a 0.1- μ F capacitor at the entry point. The front face of the bracket supports the BFO tuning capacitor, the IF GAIN switch, and the band switch. A small aluminum corner bracket at the top of the L-shaped bracket (as shown) attaches the baseband amplifier board to the assembly.

Once wiring is completed, the assembly is mounted inside the larger chassis, and the hardware for the front-panel controls attaches the assembly to the front panel. Another small aluminum bracket attaches the opposite end of the box to the bottom of the chassis for stability. The minibox assembly will, with care and patience, fit inside the larger chassis even though the rotary dial is slightly larger than the back opening and must be inserted at an angle until inside the chassis.

Because the receiver has more than 100 dB of audio gain available, good shielding, adequate power supply decoupling and careful grounding are required to prevent feedback when all controls are set for maximum gain. Use high-quality shielded cable for audio connections, and connect grounds of the baseband amplifier, phase shifter, and audio boards only via the shields of these cables. The headphone and speaker leads are

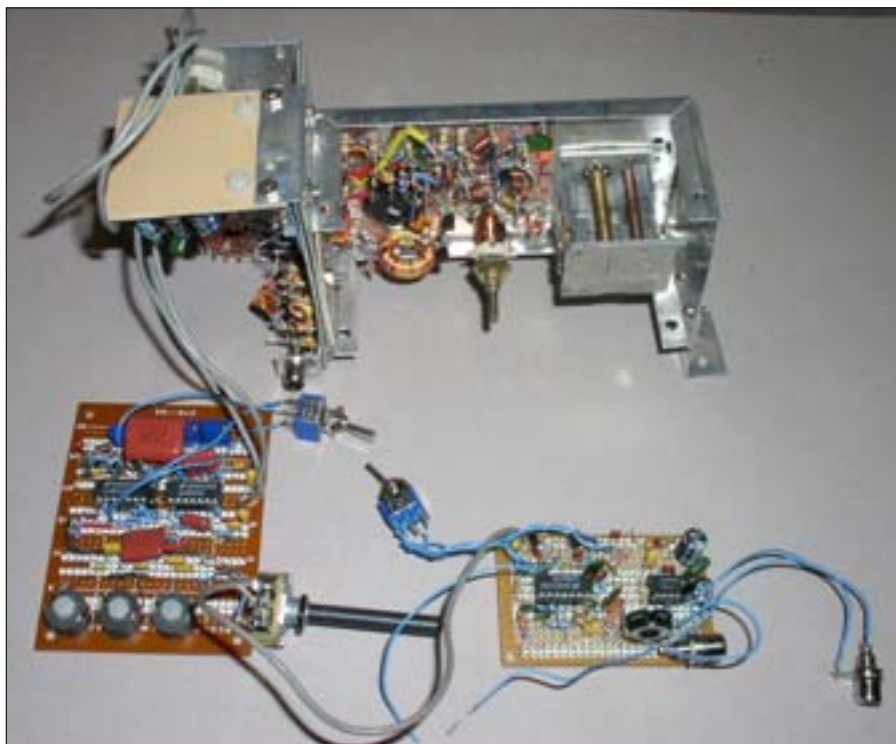

Fig 11—The receiver units prewired and tested together prior to mounting them inside the chassis.



Fig 12—The position of the brass fitting soldered to the bottom of the dial-drive drum. A $\frac{1}{2}$ -inch-long cutout in the cylinder completes the drum.

twisted-pair, grounded only at the audio board, so insulated jacks are required. Using only these ground connections will avoid potentially troublesome ground loops and microphonics. The interconnecting cables are intentionally made long so that the units may be prewired and tested to-

gether prior to mounting them inside the chassis, as shown in Fig 11.

Back-panel connectors are mounted on the lower lip of the chassis at the rear. These are 12 V dc input, mute control, line-level audio out, sidetone in, and speaker. When all wiring is complete, an optional back panel with

Appendix I – A Homebrew Dial Drive

You can build the dial mechanism shown here from a coffee can, a potentiometer, a tuning knob, a small spring, and about 18 inches of radio-quality dial cord. From the coffee can and tuning knob you construct a dial drum that fits onto the variable capacitor shaft and supports the rotary dial. You modify the potentiometer to create a tuning shaft. The spring maintains tension on the dial cord that connects the shaft to the drum. The drum is 4 inches in diameter and the tuning shaft is ¼-inch diameter, so the mechanical advantage (turns ratio) is 16:1, slow enough to tune SSB or CW signals without difficulty.

The dial drum is fashioned from the top and bottom of a 4 inch-diameter tin can. Do not use aluminum or paper since soldering is required. Use the kind that is vacuum packed with a removable foil top under a plastic cover. This type of can has a support ring inside the open end that keeps it circular. Not to advertise, but at least one variety of Yuban coffee has that feature, and I'm sure there are others. If there is paint on the cylinder, remove it for about the first half inch below the rim using fine sandpaper or paint remover. The top end of the can must be carefully severed about ¼ inch below the rim around the circumference of the cylinder. The plastic cover comes in handy for marking the cut line. I used a Dremel tool with a fine cutting disk to make that cut after it was carefully marked, but you could use tin snips. The important thing is that the cut edge must fit flush on a flat surface. The bottom end of the can is cut away from the cylinder just at its rim and filed smooth. You then have a disk with a rim that adds to its rigidity.

These two parts must be soldered together to form a narrow drum with rims that keep the dial cord in place as the drum rotates. Place the convex side of the bottom disk against the cut cylinder of the top end, and hold them in place temporarily with spring-type wooden clothespins. Then solder-tack the joint at several points inside the cylinder after which the clothespins may be removed. Finally, melt a light coat of solder continuously and smoothly around the joint on the outside, filling the joint and any small cracks resulting from an imperfect fit. Then use a fine file or sandpaper to smooth the solder joint. The dial cord must ride on the surface of the cylinder without binding.

A plastic tuning knob with a setscrew is the source of the ¼-inch ID brass fitting needed to attach the drum to the capacitor shaft. First remove the setscrew and set it aside for future use. Then crush the plastic knob in a vice or cut the plastic away until the brass fitting is free. (*Wear eye protection.*) Apply pressure only along the axis of the knob to avoid damaging the brass fitting. That fitting is now soldered to the drum bottom, facing away from the drum. It will extend sufficiently to provide about 1/8 inch clearance between the drum and the capacitor mounting surface.

First, locate the exact center of the drum. The unused plastic cover may have a tiny molding protrusion at its center that can be used for that purpose. Starting with a small pilot drill and as accurately as possible, drill a ¼-inch hole at the center for alignment with the brass fitting. Prepare the solder surfaces of both parts by sanding them clean and tinning them with a thin coat of solder on the surfaces to be attached. To hold the parts in place during soldering, I used a jig consisting of a short ¼-inch dowel inserted in a perpendicular ¼-inch hole made with a drill press in a flat block of wood. Press the parts together over the jig and solder them securely. It takes some time to heat the parts sufficiently for solder to flow freely around the joint. Be careful to keep solder from getting into the setscrew hole. Fig 12 shows the position of the brass fitting soldered to the bottom of the drum.

To complete the drum, we need a ½-inch long cutout in the cylinder as shown in Fig 12. First, drill a hole as wide as the cylinder between the rims. Then, cut slits at both rims about ¼ inch in each direction from the hole. A Dremel tool or a sharp knife can be used to make those cuts. This creates two tabs that can be bent down into the cylinder so that the cord will pass harmlessly over rounded surfaces at the bends. Finally, install two ¼-inch-long machine screws in holes drilled in the bottom surface of the drum opposite the slot just created. The ends of the dial cord and spring will be attached to those screws. The completed drum may now be mounted on the variable capacitor shaft and locked in place with the setscrew. Use some leftover nail polish to prevent the setscrew from turning. (Glyptol is the mil-spec chemical of choice, but nail polish will do.)

The potentiometer must be modified to become a smooth-turning drive shaft. First, remove the back cover, then remove the stationary wafer that contains the resistor surface and connectors by chipping it away with side cutters or pliers. Retain the plastic rotary wafer at the end of the shaft as an end stop for the shaft. Remove the metal wiper that previously contacted the resistor surface by pulling it away carefully without damaging the plastic wafer. The remaining parts are a smoothly rotating shaft in a bushing that will be mounted an inch or so from the rim of the dial drum. Potentiometers are lubricated with a viscous jelly that offers slight resistance to rotation so that the shaft does not rotate unintentionally. Do not remove that lubricant. It is harmless (it will not leak onto the external part of the shaft), it prevents wear, and it allows the dial to turn smoothly but hold its position when released. No, you can't spin the dial as some like to do, but that luxury will not be necessary in this application.

To prevent slippage of the dial cord, use a sharp tool to scribe parallel scratches in the direction of the shaft from the bushing about ¾ inch forward all around the shaft where the cord will engage it. Then lightly sand the surface to remove any sharp edges while leaving the scribed grooves for friction.

With the shaft and dial drum mounted securely, the dial cord can be installed. Fig 13 shows how the cord is routed: 1½ turns around the drive shaft, 2 turns around the drum with the ends through the slot. Thus, the cord is tangential to the drum throughout the 180° rotation of the variable capacitor. One end of the cord is attached to one of the machine screws opposite the slot in the drum cylinder, and the other end is tied to a spring attached to the other screw. Adjust the length of the cord for sufficient spring tension to prevent slipping on the drive shaft. As the dial is rotated, the cord will travel about ½ inch along the shaft length, over the prepared non-slip surface, while the spring keeps the tension constant.

To support the dial face, epoxy a ½-inch-wide ring of cardboard inside the dial drum resting on the narrow inner ring as shown in Fig 14. A circular dial face may then be glued to the cardboard ring with rubber cement. This allows it to be removed or repositioned. Before the plastic window is mounted inside the chassis front panel, temporarily install the oscillator/RF/IF assembly with the dial drum attached. Temporary markings can be made on a trial dial face at convenient frequency increments. Using the trial dial face as a template, make a final dial face on glossy paper by hand or with a computer graphics program and attach it to the cardboard ring with rubber cement. Fig 1 shows a computer-printed dial with major

marks every 100 kHz from 0 to 5 with frequencies for 80 and 40 meters. Minor marks are placed at 25-kHz increments. In this particular configuration, the indicated frequency decreases from left to right as the tuning capacitor is rotated clockwise from maximum to minimum capacitance. If you wish, cross over the dial cord between the tuning shaft and the dial drum for opposite rotation. A clear plastic "window" is attached to the inside of the chassis over the dial opening with masking tape. A thin magnet wire, also held in place with tape inside the chassis, be-

comes the dial index line.

While it certainly does not approach digital accuracy, this drive tunes smoothly with no discernable backlash. If constructed with care, it will rival an expensive anti-backlash gear drive and outperform a planetary drive, assuming they could be found. A companion transmitter section is now in development, and it will share the receiver's oscillators for transceive operation. I'm planning for digital frequency readout in that unit because transmitter frequency must be more carefully controlled.



Fig 13—The dial-cord routing: 1½ turns around the drive shaft, 2 turns around the drum with the ends through the slot. One end of the cord attaches to one of the machine screws opposite the drum cylinder slot. The other end ties to a spring attached to the other screw.



Fig 14—A ½-inch-wide cardboard ring glued inside the dial drum rests on the narrow inner ring.

necessary cutouts to clear the connectors may be attached. Self-adhesive plastic "feet" are mounted on the bottom of the receiver.

For appearance only, a front-panel was produced with a drawing program and printed on heavy photo-quality paper. After a few coats of clear Krylon spray were applied, it was attached to the front of the chassis with rubber cement and a bit of transparent tape at the edges.

Performance

I am well pleased with the performance of this relatively simple receiver. Its principal drawbacks are the lack of automatic gain control and a precise frequency display. In practice, however, these are minor inconveniences. A two-handed tuning procedure with one hand on the tuning knob and one on the audio gain is easily accommodated. Audio AGC in external processing would make that unnecessary for all but the strongest signals.

Theoretically, the receiver should have excellent dynamic range and third-order intercept performance, but I don't have the test equipment required for precise measurements. Nonetheless, my anecdotal observations are as follows. The receiver will dig weak CW or SSB signals out of the 80 and 40 meter "mud" as well as any I have used, and extremely strong amateur signals nearby do not produce the slightest evidence of blocking. (Of course, the 80 dB over S-9 nighttime broadcast signals on 40 meters are another matter.) Unwanted-sideband rejection is entirely adequate for SSB and single-signal CW reception in a crowded band. In fact, the effective SSB filtering is so good that zero-beat is barely audible when spot tuning the transmitter to get on frequency. The audio quality when fed to an external power amplifier and a good speaker provides natural and pleasant voice reception, and there is no ringing when the CW filter is switched in.

Something old, something new, something borrowed, but thankfully, nothing blue.

References

- ¹R. Fisher, W2CQH, "Twisted-wire Quadrature Hybrid Directional Couplers," *QST* Jan 1978, pp 21-23
- ²R. Campbell, KK7B, "High Performance, Direct-Conversion Receivers," *QST*, Aug 1992, pp 19-28.
- ³R. Campbell, KK7B, "High Performance, Single-Signal, Direct-Conversion Receivers," *QST*, Jan 1993, pp 32-40.
- ⁴G. Leinweber, VE3DNL, "The R2 Single Sideband Direct Conversion Receiver, Revisited: The R2a," *QRP Quarterly*, Oct 1996, pp 19-21
- ⁵B. Blanchard, N1EKV, "RF Phase Shifters for Phasing-type SSB Rigs," *QEX*, Jan 1998, p 34-39.
- ⁶R. Campbell, KK7B, "A Binaural I-Q Receiver," *QST* Mar 1999, pp 44-48.
- ⁷Diplexer configuration from Fig 15-31 of *The ARRL Handbook for Radio Amateurs*, 2001 (Newington: ARRL, 2000).
- ⁸D. Lyndon, AK4AA, "Accurate Measurement of Small Inductances," *QEX*, Jan/Feb 2004, pp 47-50. □□