

NOTE: The theory in this application note is still applicable, but some of the products referenced may be discontinued.

AN238

Transistor Mixer Design Using 2-Port Parameters

Prepared by: Ernest Klein
Applications Engineering

ABSTRACT

Mixer circuit design may be simplified by the use of small-signal admittance parameters. This note describes in detail the effective application of this design technique and the results derived from it. Several design examples are discussed: a mixer circuit converting a 30 MHz RF signal to a 5 MHz IF signal using a 35 MHz L. O. injection frequency with base injection for both the L. O. and RF signals; a mixer circuit with a 250 MHz RF and a 300 MHz L. O. converting to a 50 MHz IF output signal with both base and emitter injection of the L. O. and base injection of the RF signal. The discussion applies to both AGC and non-AGC type transistors.

INTRODUCTION

Mixer stages perform the function of frequency conversion in a signal chain. In receivers, mixers commonly transform the incoming signal frequency to an intermediate frequency, or transform one intermediate frequency to another in multiple conversion receivers. In transmitters, the increasing use of the suppressed carrier single sideband (SSB) mode of communication has brought about much wider usage of mixers since frequency multiplier stages cannot be used in an SSB signal chain.

Design of small signal high frequency amplifiers has reached a high degree of sophistication through two-port parameter analysis. These techniques have been well documented.^{1,3} However, literature on the theoretical and practical design aspects of the solid-state mixer is less plentiful and often less precise than the literature on amplifier design.

This report presents a design approach which is based on the popular two-port parameter amplifier design method.¹ A theoretical discussion and design method are described together with detailed descriptions of specific mixer circuits.

DESIGN CONSIDERATIONS

In the design of mixers, the following items are of considerable importance in obtaining a good overall circuit.

- (a) Frequencies
- (b) Stability

- (c) Gain
- (d) Network Design
- (e) Local Oscillator Injection
- (f) Device Selection

Each of these items are important in the circuit design considerations for the following reason:

(a) Frequencies:

Mixing action is done by means of a non-linear device, therefore, many different frequency components will be present in the output of the circuit. These frequency components may be categorized as:

1. **Spurious Mixer Products** — All frequency components in the output of mixer other than the desired sum or difference output component.
2. **“Crossovers” or “Birdies”** — Undesired mixer frequency components which fall within the mixer output passband.
3. **Intermodulation** — Distortion Products — A special class of spurious mixer products falling within the mixer output passband, and resulting from interaction between signal components fed into the mixer.

A problem with any mixer is spurious output signals. In addition to the obvious outputs of the local oscillator frequency, the input RF signal frequency, and the undesired sum or difference frequency, many other spurious output signals may be present. Many of these additional spurious outputs are due to third and higher order distortion characteristics which the non-linear device exhibits in addition to the second order distortion utilized by such a device to produce the desired mixing action.

Spurious output signals at both the desired output frequency, (classified as “Crossovers” or “Birdies”) and other frequencies may be present. The “off” frequency signals may be attenuated by tuned circuits following the mixer, but the only recourse to spurious outputs at the desired output frequency may be an entirely different mixing scheme.

Literature on the selection of mixing frequencies to minimize spurious outputs is available, hence, the subject will not be covered further here.²

Circuit diagrams are included as a means of illustrating typical semiconductor applications, consequently, complete information sufficient for construction purposes, is not necessarily given. The information in this application note has been carefully checked, and is believed to be entirely reliable. However, no responsibility is assumed for inaccuracies. Furthermore, such information does not convey to the purchaser of the semiconductor devices described any license under the patent rights of Motorola Inc. or others.

AN238

This report assumes that the designer has already selected suitable mixing frequencies and is ready to proceed with the actual mixer design.

(b) Stability:

The stability problem may be looked at basically from a two-port standpoint. In the design of high frequency amplifiers, the Linvill stability factor may be used to determine the potential stability of the transistor. The Linvill stability factor C is computed from the following expression:

$$C = \frac{|y_{12} y_{21}|}{2g_{11} g_{22} - R_e (y_{12} y_{21})}$$

If C is less than 1, the transistor is unconditionally stable. If C is greater than 1, the transistor is potentially unstable.

The C factor is a test for stability under a hypothetical worst case condition; that is with both input and output terminals of the transistor open circuited. With no external feedback, an unconditionally stable transistor will not oscillate under any combination of load and source admittances. If a transistor is potentially unstable, then with certain source and load admittances oscillations will occur.

The C factor is used to determine the potential stability of the transistor, but it is often desirable to compute the relative stability of actual circuits. Stern has defined a stability factor k for this purpose. The k factor is similar to the C factor except that it takes into account finite source and load admittances connected to the transistor. The expression for k is:

$$k = \frac{2(g_{11} + G_s)(g_{22} + G_L)}{|y_{12} y_{21}| + R_e (y_{12} y_{21})}$$

If k is less than 1 the circuit will be potentially unstable while if k is greater than 1 the circuit will be stable.

For the collector circuit of the mixer, a stability factor could be calculated at the output frequency, and for the base circuit a stability factor could be calculated at the input frequency. The greatest danger of oscillations occurs at the output frequency since the impedance level at the collector is higher.

From the k factor, we can see the desirability of having low source – impedance and load – impedance off-frequency, and therefore assured stability. If the output port presents a low impedance or short circuit at the input frequency, and the input port, presents a low impedance or short circuit at the output frequency, then oscillations will not occur.

In case it is impossible to meet the above stability conditions, as calculated from the k factor, an IF trap circuit could be used at the input of the two-port network and an RF trap circuit at the output of the two-port network.

(c) Gain:

Conversion gain is defined as

$$\frac{\text{IF Power out}}{\text{RF Power in}}$$

Depending upon the frequencies of operation, the mixer conversion gain will vary as does the gain of any amplifier designed for operation at the different frequencies. The gain, however, will be comparable to that obtained in an amplifier designed for the same IF frequency of operations.

(d) Network Design:

The primary considerations in the design of the input and output networks are conversion gain, stability, and attenuation of off frequency spurious output signals.

(e) L.O. Injection:

There are basically two methods for injecting the L.O. (Local Oscillator) signal, either base injection or emitter injection. Of these two schemes, base injection sometimes provides greater stability. Less stability problems are encountered, especially in the VHF and UHF frequency ranges, with base injection than emitter injection and these problems will be explained in a later section on Design Theory.

(f) Device Selection:

Since the transistor is a non-linear device, any transistor could be used as a mixer. However, certain characteristics make some transistors more desirable than others.

1. Frequencies: This device must be capable of operation at the input, output and local oscillator frequencies.
2. Gain: The device gain will be within 3 dB when used as a mixer as opposed to an amplifier designed at the output frequency in the unneutralized condition. Therefore, the device must be capable of the desired gain at the output frequency.
3. Depending on the application, either an AGC or a non-AGC device may be chosen.
4. A device with a low input capacity, C_{in} , provides for easier impedance matching.

DESIGN THEORY

The basic design theory of a mixer circuit will now be explained in terms of equivalent circuits with emphases on impedance matching techniques of both the input and output of the transistor to the respective Networks.

The basic mixer circuit can be explained in terms of the following equivalent circuits: For maximum circuit stability with the input circuit at the R.F. frequency, we may consider the output to be a short circuit.

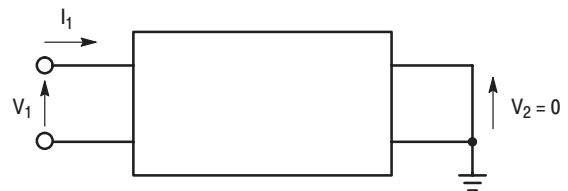

Figure 1. Equivalent Circuit: Mixer with Output Short Circuited

From the equivalent circuit

$$y_{11e} = \frac{I_1}{V_1} \Big|_{V_2 = 0}$$

For the output circuit at the I.F. frequency, and maximum circuit stability, we may consider the input circuit to be a short circuit at the I.F. frequency.

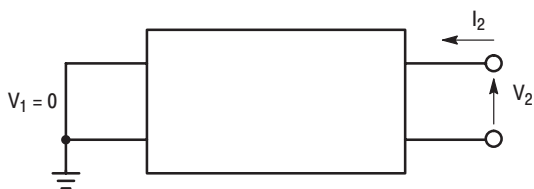

Figure 2. Equivalent Circuit: Mixer with Input Short Circuited

From the equivalent circuit

$$y_{22e} = \frac{I_2}{V_2} \Big|_{V_1=0}$$

In the above two equivalent circuits y_{11e} is the common emitter short circuit input admittance, and y_{22e} the common emitter short circuit output admittance of the transistor.

Under these conditions in the network shown in Figure 3, Y_{in} represents the input admittance of the transistor and is equal to the small signal common emitter input admittance y_{11e} at the input frequency. Y_{out} represents the output admittance of the transistor and is equal to the small signal common emitter output admittance y_{22e} at the output frequency.

For maximum conversion gain we know that the input network should be conjugately matched to the transistor input admittance. Also, the output network should be conjugately matched to the transistor output admittance. Therefore, in Figure 3, Y_{in}^* is the conjugate admittance of Y_{in} , and Y_{out}^* is the conjugate admittance of Y_{out} .

In the design of a mixer circuit using base injection for both input and L.O. signals, as long as the base does not

have sufficient drive from the L.O. signal to move operation out of the small signal region, then the small signal common emitter short circuit input admittance will be the design criteria for the source admittance. As the L.O. level is increased, however, the transistor is driven harder into conduction. The input admittance of the transistor changes to a large signal input admittance, this new large signal input admittance then becomes the design criteria for the source admittance.

Assuming operation in the small signal region, (refer to Figure 4) the source at the input frequency should constitute y_{11e} conjugate and at the output frequency a short circuit, also the load should appear as y_{22e} conjugate at the output frequency and a short circuit at the input frequency.

In Figure 5, emitter injection is used for the L.O. signal with base injection for the input signal. If the L.O. were to be injected at the emitter instead of the base, then the emitter would still have to be at R.F. ground for the input frequency but at a different impedance level for the L.O. signal. This requires more complex network design for the L.O. injection network. Of the two methods discussed for the L.O. injection, base injection and emitter injection, the base injection method is easier to work with from a stability standpoint. In the previous discussion the emitter has been at R.F. ground for the input frequency with both injection schemes. In the case of emitter injection, the emitter cannot be bypassed at the L.O. frequency. This, therefore, requires a network presenting to the emitter a short circuit at the input frequency and an impedance which is the conjugate of the L.O. source impedance at the L.O. frequency. This is a difficult design problem if the L.O. and input frequencies are close together, as they are in the VHF or UHF frequency range.



Figure 3. Network Interconnections

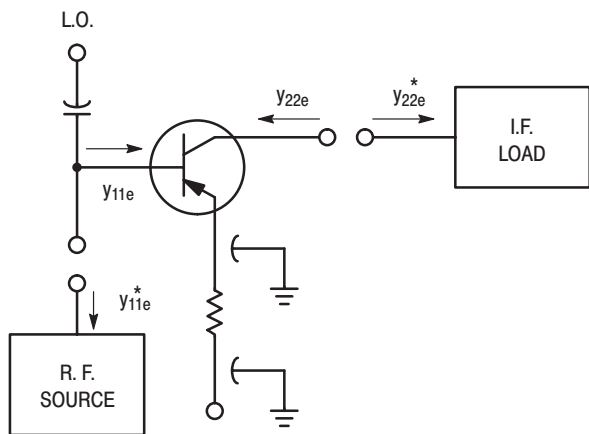

Figure 4. Base Injection of Both R.F. and L.O. Signals

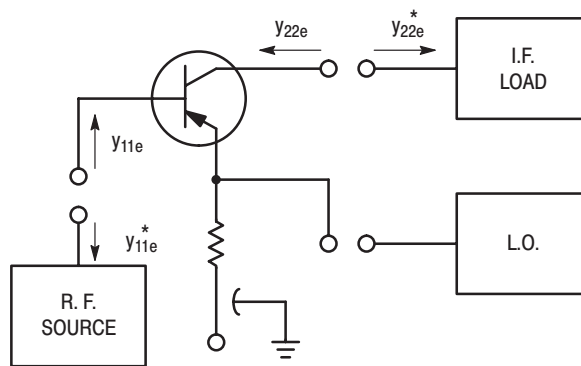

Figure 5. Base Injection of R.F. Signal and Emitter Injection of L.O. Signal

NOTE: “*”, refers to conjugate form.

AN238

MIXER CIRCUITS

The design techniques and requirements discussed in the preceding sections will now be applied to various circuit examples. These examples are of a general nature for use over the VHF and UHF frequency ranges. They have not been designed for any particular application other than to illustrate design theory and design variations. Three basic circuits are discussed: (1) a mixer converting a 30 MHz RF signal to a 5 MHz IF signal using a 35 MHz L.O. injection frequency with base injection for both the L.O. and the RF signals using a 2N2221A Motorola transistor. (2) a mixer converting a 250 MHz RF and a 300 MHz L.O. to a 50 MHz I.F. frequency using both base injection of the RF and L.O. frequencies for a Motorola MM1941 non-AGC transistor. (3) a mixer circuit of the same scheme as the above but using a Motorola 2N3308 AGC transistor. These various circuits were designed, and conversion gain measured as a function of various parameters. The results are given in this section.

The following is a mixer design using a Motorola 2N2221A transistor and converting a 30 MHz signal to a 5 MHz I.F. signal. First obtain admittance parameters at the desired frequency. For the Motorola 2N2221A ($I_C = 2$ mA, $V_{CE} = 10$ volts).

$$y_{11e} = (6.25 + j 9.5) \text{ mmhos (30 MHz)}$$

$$y_{22e} = (0.027 + j 0.28) \text{ mmhos (5 MHz)}$$

Consequently, the design criteria for the input network would be

$$1/y_{11e}^* = [160 \Omega \parallel -50.5 \text{ pF}]$$

and for the output network

$$1/y_{22e}^* = [37 \text{ k}\Omega \parallel -9.0 \text{ pF}]$$

Assume that the load the output network must be matched to is 50 ohms. Also assume the network to be of the low-pass filter type such that the higher frequencies will be attenuated, such as the one shown below.

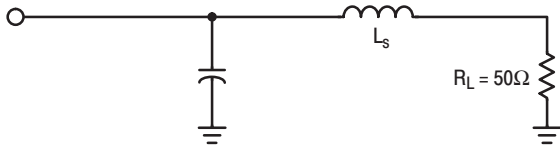

The circuit Q may be defined as follows for the series case:

$$Q_s = \sqrt{\frac{1}{G_p R_s} - 1}$$

Where G_p is the real part of the parallel admittance and R_s is the series resistance to be transformed to, represented by the 50 ohm load.

$$Q_s = \sqrt{\frac{1}{G_p R_s} - 1} = \sqrt{\frac{37\text{k}}{50} - 1} = 27.3$$

From

$$Q_s = \frac{\omega L_s}{R_s}$$

we may compute the required inductance L_s .

$$\omega L_s = R_s Q_s \therefore L_s = \frac{(27.3)(50)}{(5.0 \times 10^6)(6.28)} = 43.5 \mu\text{H}$$

The reflected parallel inductance, L_p , may be computed from

$$L_p = L_s (1 + 1/Q_s^2)$$

In the above case $L_p \approx L_s = 43.5 \mu\text{H}$. The required capacitance for resonance at 5 MHz may be calculated from

$$f = \frac{1}{2\pi \sqrt{LC}}$$

where $L = 43.5 \mu\text{H}$. In this case $C_T = 25$ pF. From the y-parameter equivalent of the transistor the imaginary part represents 9.0 pF of capacitance. Therefore, an additional capacitance of $(25.0 - 9.0)$ pF = 16 pF is needed.

For the input network, again assuming a 50 ohm termination, let a transforming network be used as illustrated below:

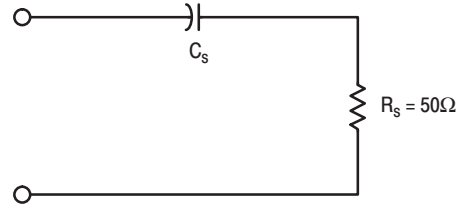

which is equivalent to:

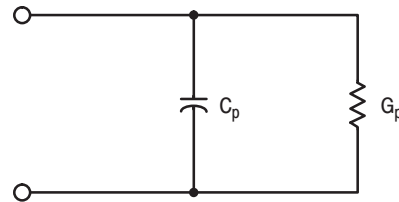

using the relationships as described above:

$$Q_s = \sqrt{\frac{1}{G_p R_s} - 1} = \sqrt{\frac{160}{50} - 1} = 1.47$$

$$Q_s = \frac{X_s}{R_s} \therefore C_s = \frac{1}{\omega Q_s R_s} = \frac{1}{(3.0 \times 10^7)(6.28)(1.47)(50)} = 72.5 \text{ pF}$$

yields:

$$C_p = C_s \frac{1}{1 + 1/Q_s^2} = \frac{72.5 \text{ pF}}{1 + (1/2.17)} = 49.5 \text{ pF}$$

The total capacitance which must be tuned out at the base is equal to $C_p + C_{in}$ of the transistor, or $49.5 + 50.5 = 100$ pF.

An inductance value of 0.22 μH was selected to permit the addition of a trimmer capacitor from base to ground.

The complete circuit is as shown in Figure 6.

The curve in Figure 7 gives conversion gain as a function of L.O. input levels for different collector currents. Since the y parameters are a function of collector current a new set of parameters were used to design the matching networks for the different collector currents.

The L.O. voltage is measured at point (A) in Figure 6. In all following circuits the L.O. voltage is measured at this point.

The following are results obtained using an MM1941 Motorola silicon NPN transistor in a 250 MHz mixer converting to a 50 MHz output frequency. The circuit, Figure 9, shows the transistor and matching networks for both the input and output. Figures 10 through 14 are curves of data obtained using the circuit shown in Figure 9.

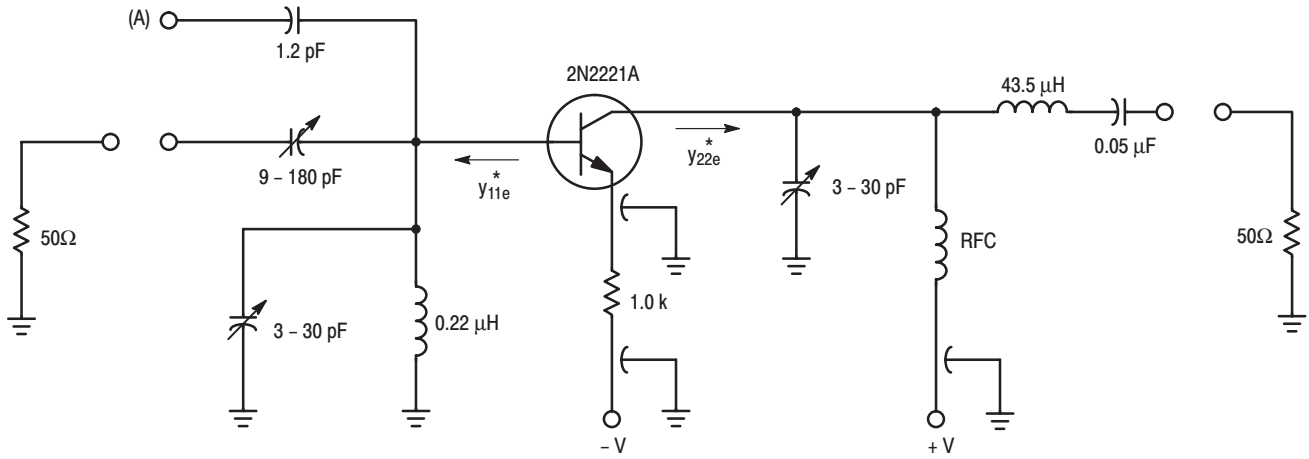

Figure 6. A 30 MHz RF to 5 MHz IF Mixer

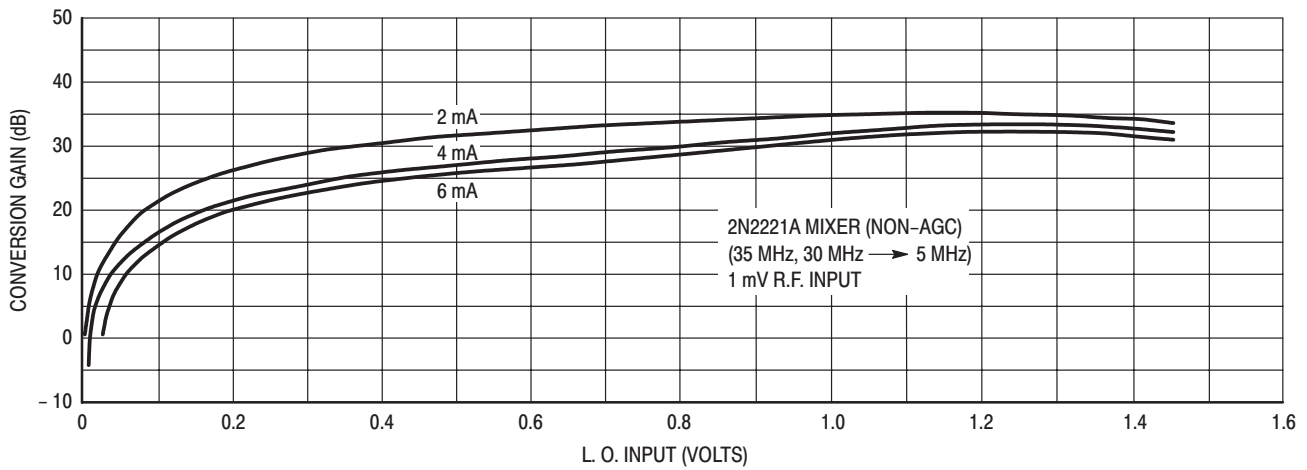

Figure 7. Conversion Gain vs L.O. Input Level Using Motorola 2N2221A Transistor

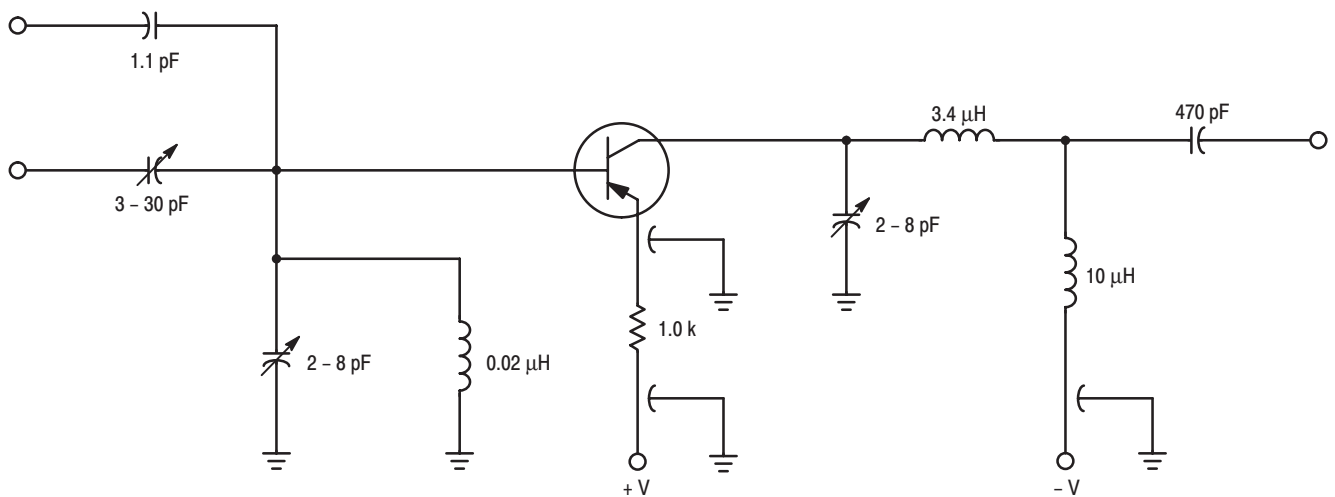

Figure 8. Circuit Diagram of 2N3308 Mixer 300, 250 MHz → 50 MHz

AN238

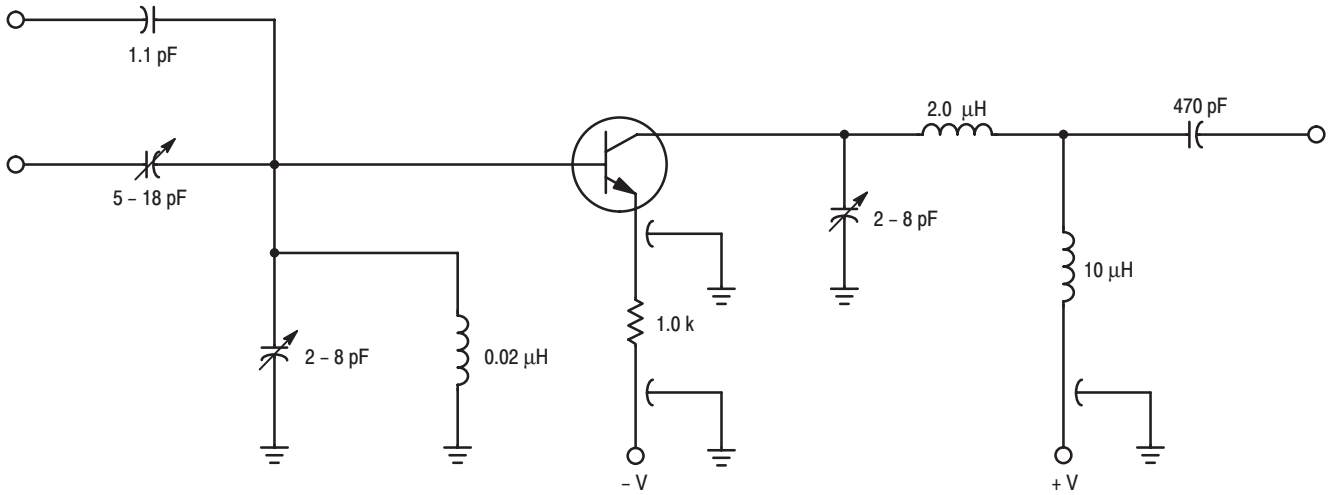

Figure 9. Circuit Diagram of MM1941 Mixer 300, 250 MHz \rightarrow 50 MHz

Figure 10 shows the relation existing between conversion gain and source admittance for changing values of RF source admittance. For the transistor being used $y_{11e} = 8.4 + j 11.5$ mmhos, and $1/y_{11e} = [119\Omega \parallel 7.3 \text{ pF}]$. Curve A shows the variation in conversion gain as the real part of the source admittance is varied while holding the imaginary constant at -7.3 pF . Curve B shows the variation in conversion gain as the imaginary part of the source admittance is varied while holding the real part constant at 119Ω . This confirms the fact that maximum conversion gain occurs very near the point where the source admittance presents to the transistor the conjugate of the transistor input admittance.

Figure 11 gives conversion gain as a function of L.O. injection capacitor size for a constant L.O. injection voltage at 300 MHz.

Figure 12 is a curve of the measured real part of the source admittance for maximum conversion gain for different levels of L.O. input voltage. Figure 13 is a curve of the measured imaginary part of the source admittance for maximum conversion gain for different levels of L.O. input voltage. These indicate that the input admittance of the transistor changes as the L.O. drive is increased and, therefore, out of the small signal region of operation of the transistor.

Figure 14 is the difference in conversion gain for different L.O. input levels when the source admittance is matched in conjugate form to the transistor parameters and when the source admittance is tuned for maximum conversion gain. As can be seen from Figure 14 maximum conversion gain occurred at an L.O. level such that operation was still in the small signal region of operation of the device.

Figure 15 gives conversion gain as a function of L.O. input voltage for different transistor currents. As can be seen at the higher current levels, the conversion gain changes somewhat over the range of L.O. input voltage while at the lower currents the conversion gain remains nearly constant.

The same design procedure was used to design a mixer circuit at 250, 300 MHz with a 50 MHz output frequency using a Motorola 2N3308 silicon PNP transistor. This is an AGC device as opposed to the MM1941 which is a non-AGC device. This transistor and its associated input and output matching networks are shown in Figure 8.

Figure 16 shows that the effect of AGC action takes place between two and four mA of collector current.

The preceding circuits are based on base injection of both the RF and L.O. signals. The emitter was always bypassed and, therefore, at RF ground.

For emitter injection of the L.O. it was found that circuit oscillations were harder to control than in the case of base injection. This would indicate that the input RF network was not appearing as a short circuit to the IF frequency. It was also found that the effect of RF signal frequency and L.O. level on conversion gain are more pronounced in this case than in the case of base injection of the L.O. Also, optimum L.O. shifts upward with increased emitter current.

CONCLUSIONS

The design examples in the preceding section of this application note showed in detail the design technique for a mixer circuit using base injection for both L.O. and RF signal inputs. The results of the mixer design are consistent with the theory explained in the preceding section. Maximum conversion gain did occur when the source admittance was the conjugate of the transistor input admittance and the load admittance the conjugate of the transistor output admittance. The best stability was obtained when the source admittance presented a short circuit to the IF frequency. The conversion gain was also found to be comparable to that attained for an amplifier designed at the IF frequency.

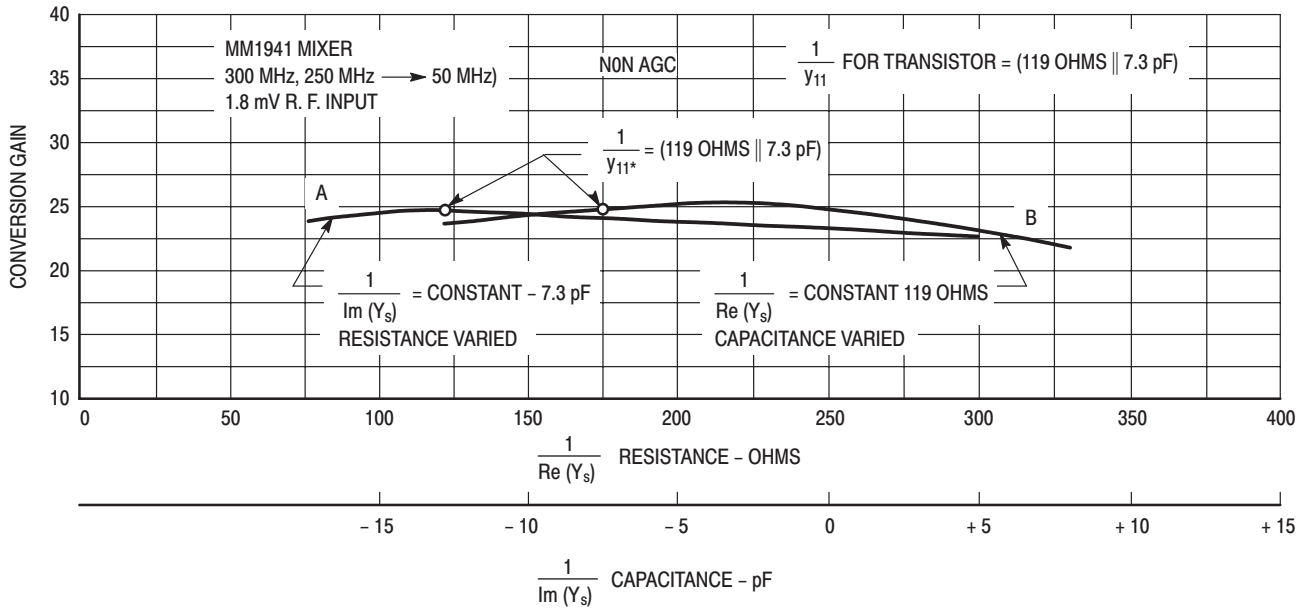

Figure 10. Gain as a Function of Source Impedance (Input Network)

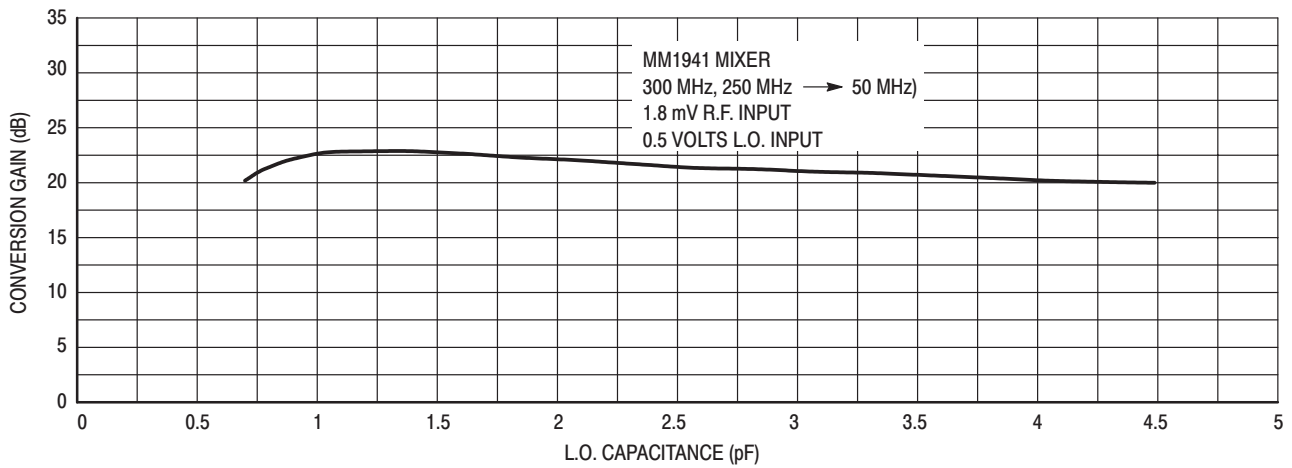

Figure 11. Gain as a Function of L.O. Input Capacitance

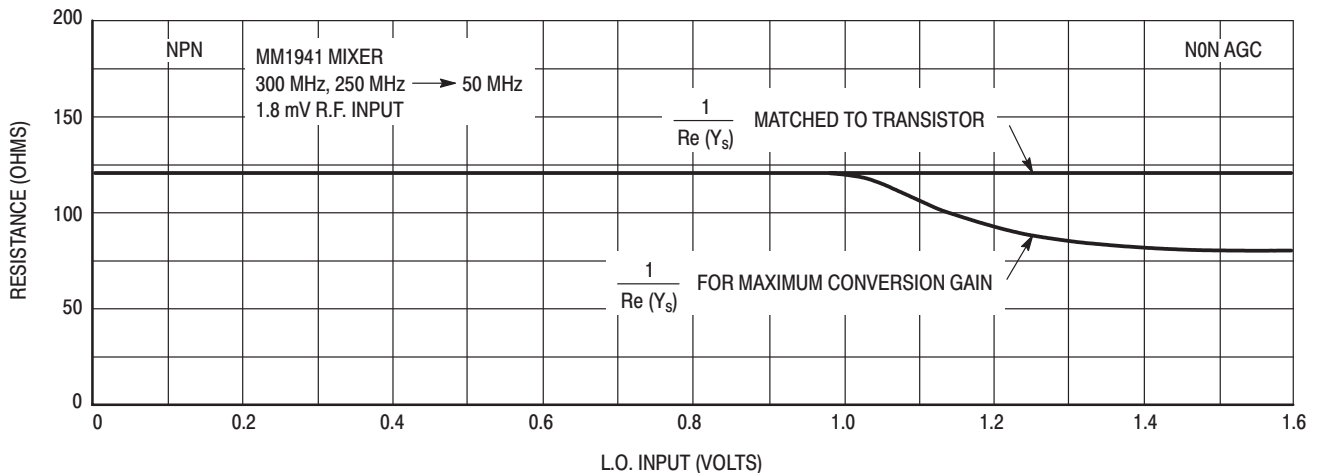

Figure 12. Optimum Input Network Resistance for Maximum Conversion Gain at Various L.O. Levels

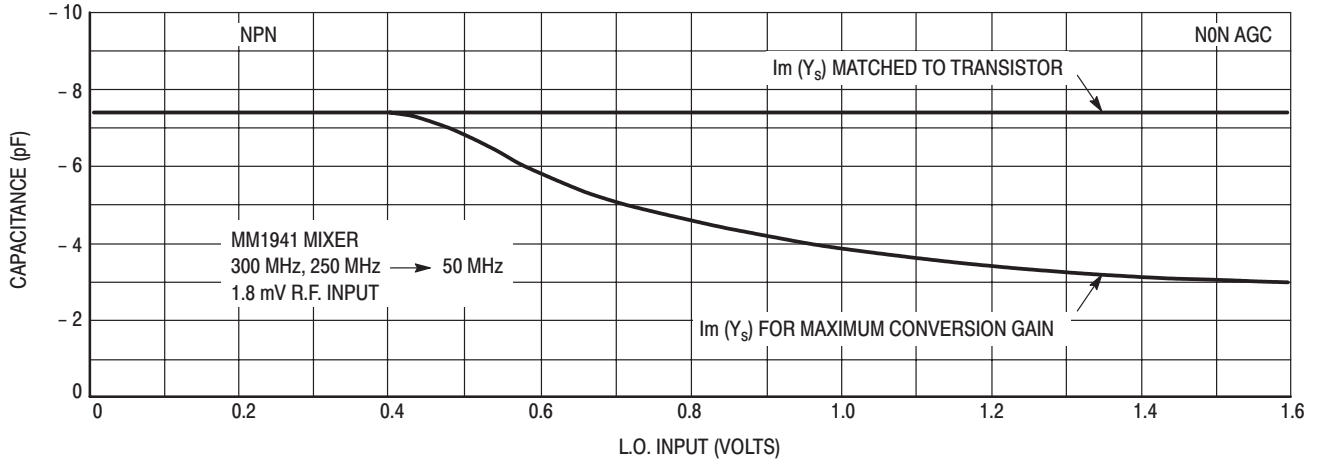

Figure 13. Optimum Input Network Inductance for Maximum Conversion Gain at Various L.O. Levels

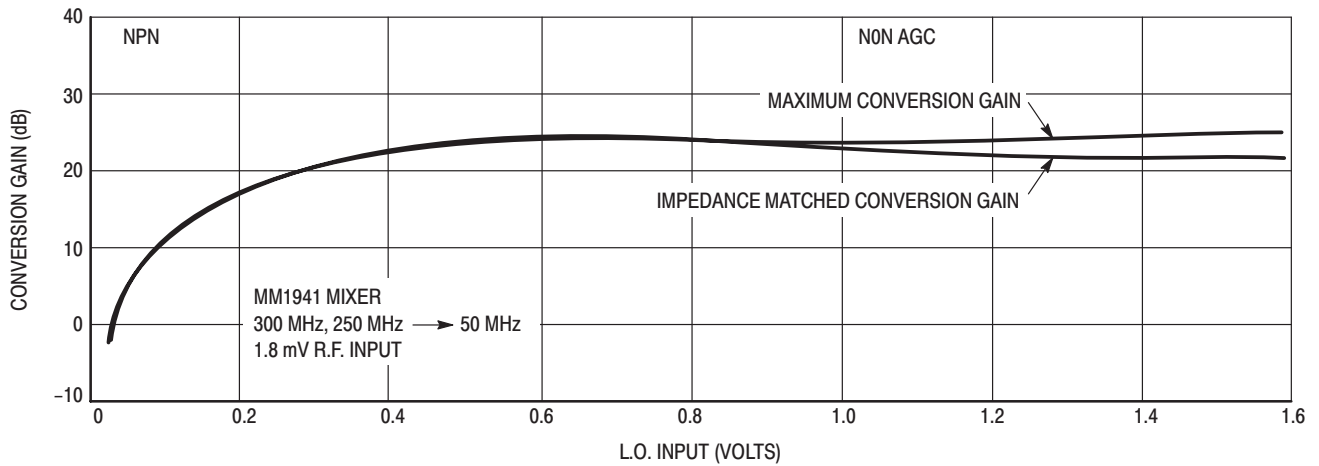

Figure 14. Impedance Matched Conversion Gain Compared with Maximum Conversion Gain

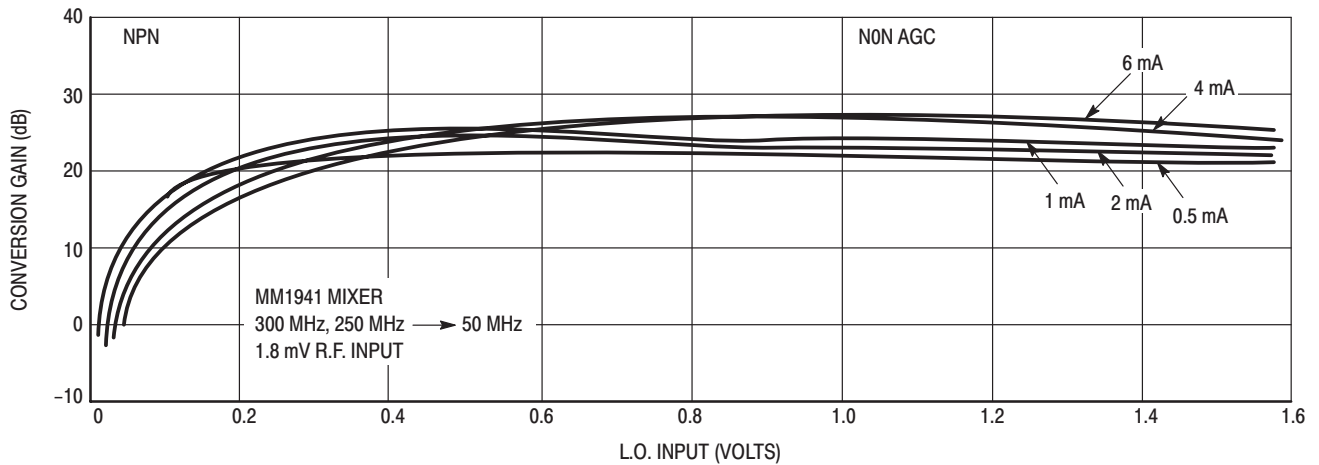

Figure 15. Conversion Gain for Different Currents

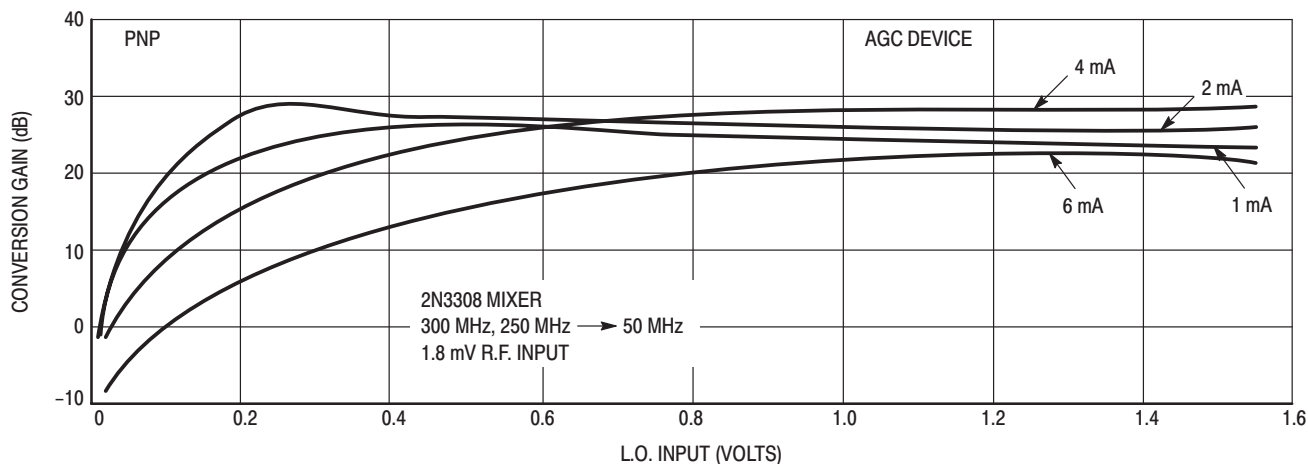

Figure 16. Conversion Gain for Different Currents

SUMMARY OF TRANSISTOR MIXER DESIGN PROCEDURE

In addition to selecting a circuit at the input to match the transistor input admittance and a circuit at the output to match the transistor output admittance, other factors must be considered. A suitable network should be chosen to reduce spurious or undesired frequency components at the output due to the non-linear character of the mixer itself. At the input, the network may be used to obtain a desired selectivity if other frequency components are available other than the desired input signal.

From the curves on conversion gain as a function of Local Oscillator input level, the following comments are evident. The level of operation can be left up to the individual designer, but is relatively unimportant as far as conversion gain goes, as long as the level does not exceed the region of small signal operation.

A suitable coupling capacitor in the VHF frequency range was found to be about 1 pF. This value, in the case of base injection, does not considerably alter the transistor input admittance appreciably from the theoretical value of y_{11e} without Local Oscillator injection.

In choosing a bias point of operation for the transistor, and neglecting noise consideration in the device and associated circuitry, a good design criteria would be the same as that used for small signal amplifier design.

The choice of either a forward AGC or a non-AGC transistor is a function of what the individual designer desires.

GLOSSARY

C = Linvill's stability factor

k = Stern's stability factor

G_S = Real part of the source admittance

G_L = Real part of the load admittance

B_S = Imaginary part of the source admittance

B_L = Imaginary part of the load admittance

g_{11} = Real part of y_{11}

g_{22} = Real part of y_{22}

BIBLIOGRAPHY

1. "RF Small Signal Design Using 2-Port Parameters," Motorola Semiconductor Products, Inc., Application Note 215A.
2. "Single Sideband Principles and Circuits," by E. Pappenfus, Warren Bruene, E. Schoenike, McGraw-Hill, 1964.
3. "Stability and Power Gain of Tuned Transistor Amplifiers," by Arthur P. Stern, Proc. IRE, March 1957.
4. "Transistor Circuit Engineering," by R. F. Shea, John Wiley and Sons, Mc., 1957.

NOTES

Motorola reserves the right to make changes without further notice to any products herein. Motorola makes no warranty, representation or guarantee regarding the suitability of its products for any particular purpose, nor does Motorola assume any liability arising out of the application or use of any product or circuit, and specifically disclaims any and all liability, including without limitation consequential or incidental damages. "Typical" parameters can and do vary in different applications. All operating parameters, including "Typicals" must be validated for each customer application by customer's technical experts. Motorola does not convey any license under its patent rights nor the rights of others. Motorola products are not designed, intended, or authorized for use as components in systems intended for surgical implant into the body, or other applications intended to support or sustain life, or for any other application in which the failure of the Motorola product could create a situation where personal injury or death may occur. Should Buyer purchase or use Motorola products for any such unintended or unauthorized application, Buyer shall indemnify and hold Motorola and its officers, employees, subsidiaries, affiliates, and distributors harmless against all claims, costs, damages, and expenses, and reasonable attorney fees arising out of, directly or indirectly, any claim of personal injury or death associated with such unintended or unauthorized use, even if such claim alleges that Motorola was negligent regarding the design or manufacture of the part. Motorola and  are registered trademarks of Motorola, Inc. Motorola, Inc. is an Equal Opportunity/Affirmative Action Employer.

Literature Distribution Centers:

USA: Motorola Literature Distribution; P.O. Box 20912; Phoenix, Arizona 85036.

EUROPE: Motorola Ltd.; European Literature Centre; 88 Tanners Drive, Blakelands, Milton Keynes, MK14 5BP, England.

JAPAN: Nippon Motorola Ltd.; 4-32-1, Nishi-Gotanda, Shinagawa-ku, Tokyo 141, Japan.

ASIA PACIFIC: Motorola Semiconductors H.K. Ltd.; Silicon Harbour Center, No. 2 Dai King Street, Tai Po Industrial Estate, Tai Po, N.T., Hong Kong.

